

For Serial Nos.
670,000 & Higher

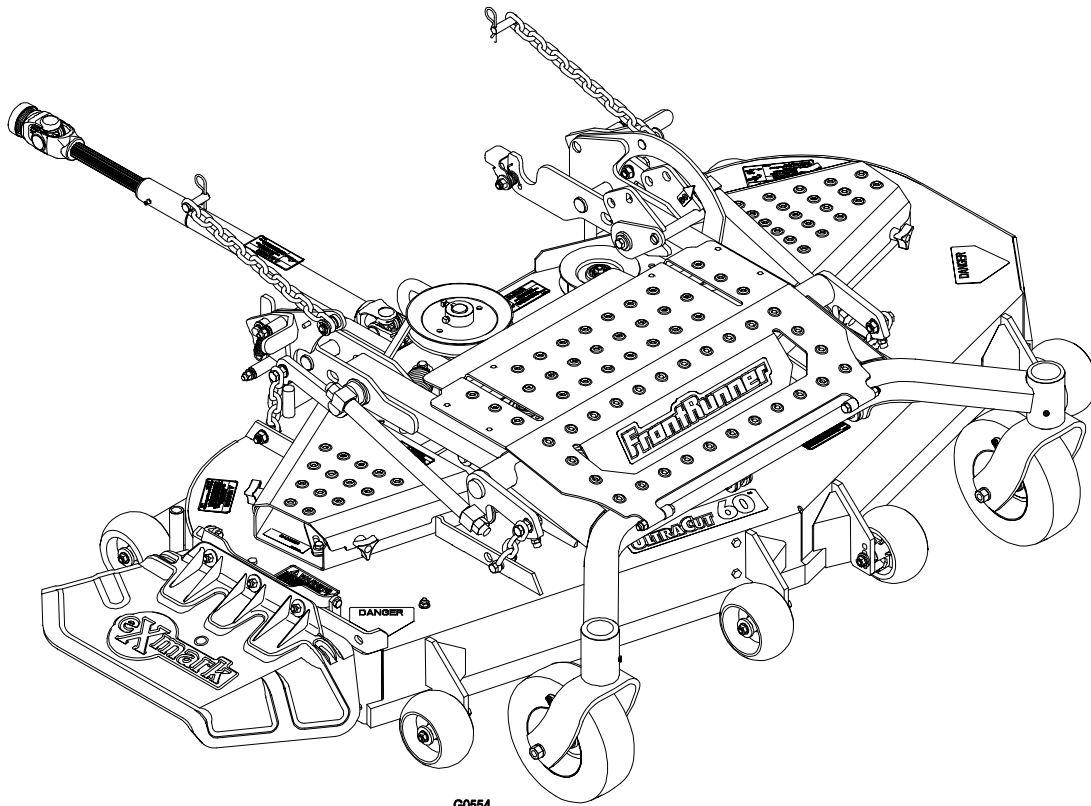

FRONTRUNNER FR524/FR604/FR724

CONGRATULATIONS on the purchase of your new Exmark equipment. This product has been carefully designed and manufactured to give you a maximum amount of dependability and years of trouble-free operation. If additional information is needed, or should you require trained mechanic service, contact your authorized Exmark equipment dealer or distributor. If you need to order replacement parts from your dealer, always give the model number and serial number of your equipment as well as the part number, description and quantity of the part needed.

The Serial No. plate is located on the rear right hand belt cover support under the front frame. For ease of ordering and reference, we suggest that you record the information requested in the following identification table.

Place Model No. and Serial No. Label Here (Included in Literature Pack) or Fill in Below
Model No. _____
Serial No. _____

Date Purchased _____

OPERATOR'S & PARTS MANUAL

EXMARK PARTS PLUS® PROGRAM

EFFECTIVE DATE: September 1, 1995

Program

If your Exmark dealer does not have the Exmark part in stock, Exmark will get the parts to the dealer the next business day or the part will be FREE* Guaranteed!!

How the Program Works

1. If dealer does not have part in stock for a "down" unit at the time of request by customer, the dealer contacts his distributor by 1:00 p.m., local time, and requests Exmark Parts Plus® shipment of six (6) line items or less.
2. Distributor ships part(s) to dealer or customer, as requested by dealer, same day, overnight UPS. Distributor bills dealer for part and freight charges where applicable.
3. If distributor does not have the part(s) in stock to satisfy Exmark Parts Plus® order, he contacts Exmark by 3:00 p.m., central time, with an Exmark Parts Plus® order of six (6) line items or less.
4. If order is received by 3:00 p.m. central time, Exmark ships part(s) direct to dealer or customer, as requested by distributor, same day, overnight UPS, Exmark bills the distributor for parts and shipping charges, where applicable.
5. The customer pays for the part and freight if it is shipped under the Exmark Parts Plus® and if it arrives in accordance to the program.
6. Who pays for the part and freight if it fails to arrive overnight in accordance to the program?
 - A. Under any circumstance the customer does not pay.
 - B. If the part does not arrive overnight due to:
 1. The dealer not submitting the Exmark Parts Plus® order to his Exmark distributor by 1:00 p.m., the dealer pays for the part and freight.
 2. The Distributor being unable to ship the part the same day or not submitting the Exmark Parts Plus® order to Exmark by 3:00 p.m., central time, the Distributor pays for the part and freight.
 3. Exmark being unable to ship the part and the Exmark parts order is received by 3:00 p.m., central time, Exmark pays for the part and freight.
 4. If the part does not arrive overnight due to the shipper (UPS), the shipper pays for the freight and Exmark pays for the part.

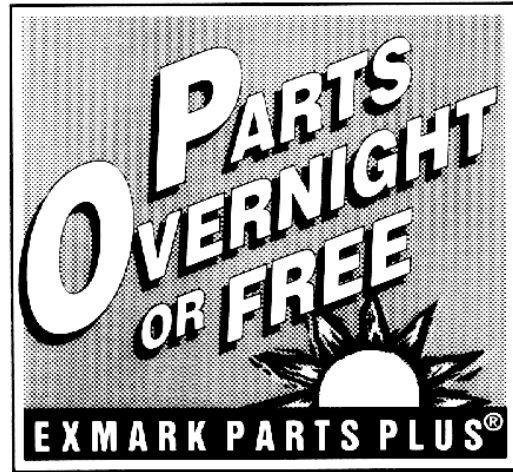

The following restrictions apply -- The Exmark Parts Plus® Program is available only through participating Exmark Dealers and applies only to orders submitted on this program Monday through Thursday. Parts Plus service is available only in the 48 contiguous United States. UPS has initiated a Saturday delivery program to many areas of the continental United States and can be requested for an overnight shipment on Friday to be delivered Saturday. The next day air charge, plus the Saturday delivery fee will be the responsibility of the purchaser. Exmark Mfg. will assume no responsibility for Saturday delivery shipments. To qualify, all Exmark Parts Plus® orders must be received by Exmark by 3:00 p.m., central time. Orders must be six (6) line items or less. Exclusions from the Exmark Parts Plus® Program are: Any wholegood or accessory in its entirety, engines and engine replacement parts, 5-speed Peerless transmissions and 5-speed transaxles, hydraulic or hydrostatic wheel motors, cutter decks and engine decks or any item exceeding United Parcel Service size and weight restrictions.

Due to UPS restrictions, aerosol spray paint is considered a hazardous material and cannot be shipped via UPS next day or Second Day Air.

Exmark Manufacturing stocks a limited supply of parts for transaxles, pumps and wheel motors. These parts can be ordered for Next Day Air shipment but will not be guaranteed per the Parts Plus Program.



WARNING



POTENTIAL HAZARD

- ◆ This product is a piece of power equipment.

WHAT CAN HAPPEN

- ◆ Failure to follow safe operating practices can result in serious operator injury or even death.

HOW TO AVOID THE HAZARD

- ◆ Keep all shields, guards, and safety devices (especially the grass discharge system) in place and in proper working condition.
- ◆ Stop engine and wait for all moving parts to stop and engage parking brake. Remove spark plug wire(s) or remove key before adjusting, servicing, or performing maintenance.
- ◆ If mower deck becomes clogged, stop engine and wait for all moving parts to stop. Remove spark plug wire(s) or remove key before cleaning blockage.
- ◆ Keep hands, feet, and clothing away from power driven parts.
- ◆ Keep off mower unless seat platform is provided.
- ◆ Keep others off mower.

CONGRATULATIONS on the purchase of your Exmark FrontRunner Cutting Deck. This product has been carefully designed and manufactured to give you a maximum amount of dependability and years of trouble-free operation.

OPERATOR'S MANUAL

This manual contains assembly, operating, maintenance, adjustment, and safety instructions for your FrontRunner Cutting Deck.

BEFORE OPERATING YOUR MOWER, CAREFULLY READ THIS MANUAL IN ITS ENTIRETY.

By following the operating, maintenance, and safety instructions, you will prolong the life of your equipment, maintain its maximum efficiency, and promote safe operation.

If additional information is needed, or should you require trained mechanic service, contact your authorized Exmark equipment dealer or distributor.

All Exmark equipment dealers and distributors are kept informed of the latest methods of servicing and are equipped to provide prompt and efficient service in the field or at their service stations. They carry ample stock of service parts or can secure them promptly for you from the factory.

All Exmark parts are thoroughly tested and inspected before leaving the factory, however, attention is required on your part if you are to obtain the fullest measure of satisfaction and performance.

TABLE OF CONTENTS

	PAGE
1. SAFETY	
1.1 Safety Alert Symbol	1
1.2 Training	1
1.3 Preparation.....	1-2
1.4 Operation	2
1.5 Maintenance & Storage	2
1.6 Safety Signs	2-3
2. SPECIFICATIONS	
2.1 Model Numbers	4
2.2 Dimensions.....	4
2.3 Torque Requirements.....	4
3. ASSEMBLY INSTRUCTIONS	
3.1 Assemble Deck to FrontRunner.....	4-6
3.2 Deck Removal	6-7
4. MAINTENANCE & ADJUSTMENTS	
4.1 Deck Raising and Lowering	7-9
4.2 Maintenance.....	9-12
4.3 Adjustments	12-14
5. PARTS LIST	
5.1 Deck Group	15-17
5.2 Spindle Assembly	18
5.3 Front Frame Group.....	19-20
5.4 Decal Group	21
6. WARRANTY	22

1. SAFETY

1.1 SAFETY ALERT SYMBOL

This SAFETY ALERT SYMBOL  is used both in this manual and on the unit to identify important safety messages which must be followed to avoid accidents. This symbol means:

**ATTENTION! BECOME ALERT!
YOUR SAFETY IS INVOLVED!**

The safety alert symbol appears above information which alerts you to unsafe actions or situations and will be followed by the word **DANGER**, **WARNING**, or **CAUTION**.

DANGER: White lettering / Red background. Indicates an imminently hazardous situation which, if not avoided, **WILL** result in death or serious injury.

WARNING: Black lettering / Orange background. Indicates a potentially hazardous situation which, if not avoided, **COULD** result in death or serious injury.



CAUTION: Black lettering / Yellow background. Indicates a potentially hazardous situation which, if not avoided, **MAY** result in minor or moderate injury.

1.2 TRAINING

- 1.2.1 Regard the Exmark mower as a piece of power equipment and teach this regard to all who operate this unit.
- 1.2.2 Before operating your mower, read the FrontRunner tractor and cutting deck manual instructions carefully. Familiarize yourself with the controls and the proper use of the equipment. If the operator(s) or mechanic(s) can not read English, it is the owner's responsibility to explain this material to them.
- 1.2.3 Do not allow operation of this machine by untrained personnel. Never allow children, teenagers, or people unfamiliar with these instructions to use the mower. Local regulations may restrict the age of the operator.
- 1.2.4 Avoid mowing while people, especially children, or pets, are nearby. Keep in mind that the operator or user is responsible for accidents or hazards occurring to other people or their property.

1.3 PREPARATION



- 1.3.1 Do not modify the FrontRunner cutting deck and only use on approved Exmark machines.
- 1.3.2 The use of personal protective equipment, such as (but not limited to) protection for the eyes, ears, feet, and head is recommended.

 WARNING 	
POTENTIAL HAZARD	◆ This machine produces sound levels in excess of 85 dBA at the operator's ear when in operation.
WHAT CAN HAPPEN	◆ Exposure to sound levels of 85 dBA or above for extended periods of time can cause hearing loss.
HOW TO AVOID THE HAZARD	◆ Wear hearing protection when operating this machine.

- 1.3.3 While mowing, always wear substantial footwear and long trousers. Do not operate equipment when barefoot or when wearing open sandals.
- 1.3.4 Thoroughly inspect the area where the equipment is to be used and remove all stones, sticks, wires, bones, and other foreign objects which may damage the equipment or cause personal injury to the operator or bystanders.

1.4 OPERATION

Although hazard control and accident prevention are partially dependent upon the design and configuration of the equipment, these factors are also dependent upon the awareness, concern, prudence, and proper training of the personnel involved in the operation, transport, maintenance, and storage of the equipment. It is essential that all Operator Safety Mechanisms be connected and in operating condition prior to use for mowing.

 WARNING 	
POTENTIAL HAZARD	
<ul style="list-style-type: none"> ◆ Hands, feet, hair, clothing, or accessories can become entangled in rotating parts. 	
WHAT CAN HAPPEN	
<ul style="list-style-type: none"> ◆ Contact with rotating parts can cause traumatic amputation or severe lacerations. 	
HOW TO AVOID THE HAZARD	
<ul style="list-style-type: none"> ◆ Do not operate the machine without guards, shields, and safety devices in place and working. ◆ Keep hands, feet, hair, jewelry, or clothing away from rotating parts. 	

- 1.4.1 Give complete, undivided attention to the job at hand.
- 1.4.2 Mow only in daylight or good artificial light, keeping away from holes and hidden hazards. **NEVER** carry passengers.
- 1.4.3 Use **EXTREME** caution when backing up. **LOOK BEHIND YOU!**
- 1.4.4 Stop the blades when crossing surfaces other than grass and when transporting the mower to and from the area to be mowed.
- 1.4.5 Never operate the mower with damaged guards, shields, or covers. Always have safety shields, guards, switches, and other devices in place and in proper working condition.

1.5 MAINTENANCE AND STORAGE

- 1.5.1 Check all bolts frequently to maintain proper tightness.
- 1.5.2 Keep all guards, shields, and all safety devices in place and in safe working condition.
- 1.5.3 Frequently check for worn or deteriorating components that could create a hazard.
- 1.5.4 All replacement parts must be the same as or equivalent to the parts supplied as original equipment.

1.6 SAFETY SIGNS

- 1.6.1 Keep all safety signs legible. Remove all grease, dirt and debris from safety signs and instructional labels.
- 1.6.2 Safety signs must be replaced if they are missing or illegible.

- 1.6.3 When new components are installed, be sure that current safety signs are affixed to the replaced components.
- 1.6.4 New safety signs may be obtained from Exmark Mfg. Co. Inc.
- 1.6.5 Safety signs may be affixed by peeling off the backing to expose the adhesive surface. Apply only to a clean, dry surface. Smooth to remove any air bubbles.
- 1.6.6 Familiarize yourself with the following safety signs and instruction labels. They are critical to the safe operation of your Exmark commercial mower.



PART NO. 1-303508
LOCATION: On RH Side of Deck by Discharge

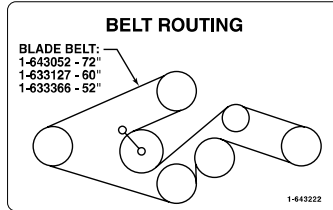

PART NO. 1-643222
LOCATION: On Top of Deck Between Sheaves

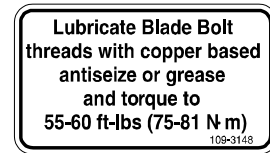

PART NO. 109-3148
LOCATION: On LH Front Side of Deck by Chain Mount



PART NO. 1-403005
LOCATION: On Top Front Corners of Deck

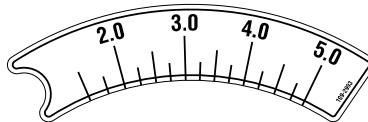

PART NO. 109-2993
LOCATION: On Front Frame

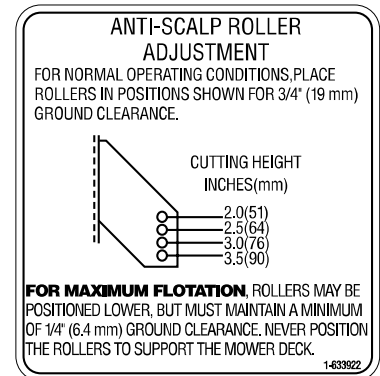

PART NO. 1-633922
LOCATION: On Top Front Center of Deck



PART NO. 98-5954
LOCATION: On Top of Deck, Under Belt Covers



PART NO. 109-2354
LOCATION: On Top of LH & RH Belt Covers



PART NO. 103-8425
LOCATION: 1) On Driveshaft
2) On LH side of Deck by Gearbox Sheave

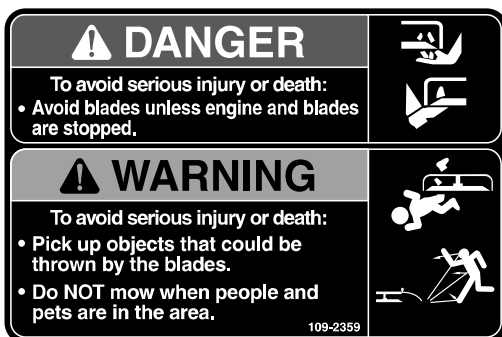

PART NO. 109-2359
LOCATION: Top LH Rear Corner of Deck

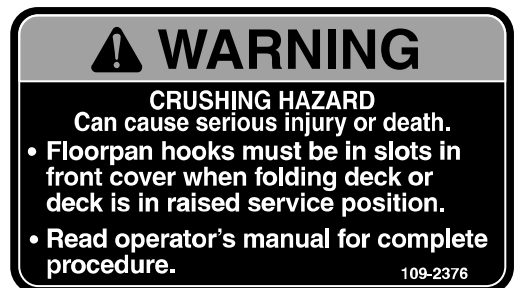

PART NO. 109-2376
LOCATION: Top RH Rear Corner of Deck

2. SPECIFICATIONS

2.1 **MODEL NUMBERS:** FR524; FR604, FR724

2.2 DIMENSIONS

	52" Deck	60" Deck	72" Deck
Overall Width (chute down)	64.6" (164.1 cm)	72.7" (184.7 cm)	84.4" (214.4 cm)
Overall Width (chute up)	53.9" (136.9 cm)	61.4" (156.0 cm)	73.3" (186.2 cm)
Overall Height	18.0" (45.7 cm)	18.0" (45.7 cm)	18.0" (45.7 cm)
Overall Length	42.5" (108.0cm)	42.3" (107.4 cm)	45.5" (115.6 cm)
Weight	393 lbs. (178 kg)	434 lbs. (197 kg)	514 lbs (233 kg)



2.3 TORQUE REQUIREMENTS

Bolt Location

Torque

Blade Mounting Bolt.....	55-60 ft-lbs. (75-81 N-m)
Gearbox Mounting Bolts	16-18 ft-lbs. (22-24 N-m)
Drive Shaft Set Screw.....	18 ft-lbs. (24 N-m)
Drive Shaft Pinch Bolt.....	44 ft-lbs. (60 N-m)
Cutter Housing spindle Nut.....	140-145 ft-lbs. (190-197 N-m)
Anti-Scalp Roller – Whizlock Nut.....	40-45 ft-lbs. (54-61 N-m)

3. ASSEMBLY INSTRUCTIONS

 WARNING 
<p>POTENTIAL HAZARD</p> <ul style="list-style-type: none"> ◆ Operating a FrontRunner tractor without an approved Exmark front mount attachment increases the possibility of forward tip over.
<p>WHAT CAN HAPPEN</p> <ul style="list-style-type: none"> ◆ Tip-over could cause serious injury or death.
<p>HOW TO AVOID THE HAZARD</p> <ul style="list-style-type: none"> ◆ When operating a FrontRunner tractor without an approved Exmark front mount attachment, observe the following: <ul style="list-style-type: none"> * Limit operation to minimum required to install a different front mount attachment. * Minimize speed and use extreme caution. * Only operate on a flat level surface. * Do not operate up or down a trailer ramp. * Avoid sudden acceleration or deceleration.

3.1 ASSEMBLE DECK TO FRONTRUNNER

IMPORTANT: Do not transport FrontRunner tractor without an approved Exmark front mount attachment.

3.1.1 Stop engine, wait for all moving parts to stop and remove key. Engage parking brake.

3.1.2 Rotate the fold lock lever, located on the front frame, in the unlocked position.
(See Figure 1).

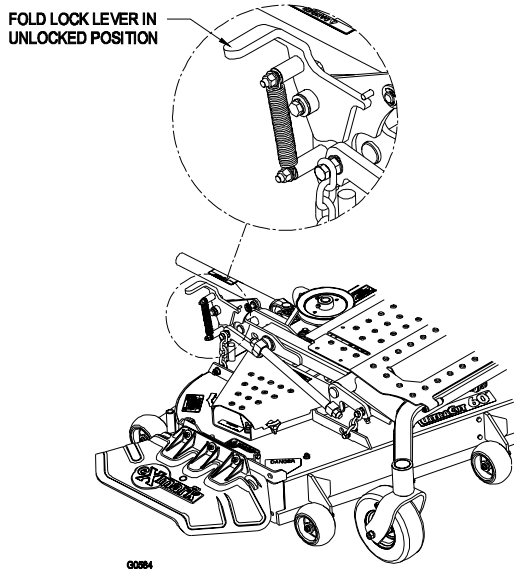

FIGURE 1

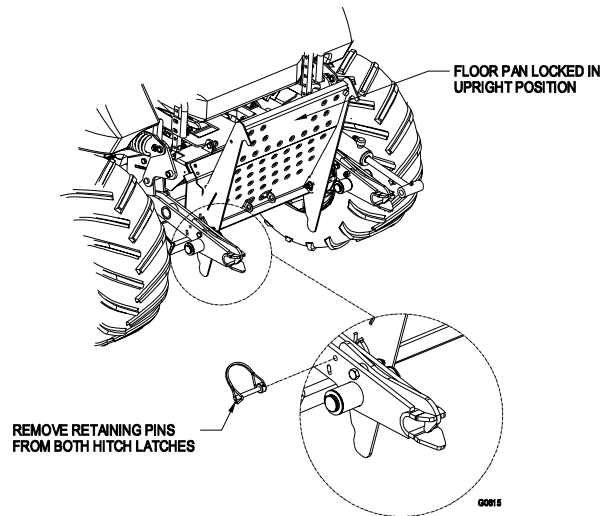

FIGURE 2

3.1.3 On the tractor, release the two retaining pins on the hitch latches so the latches can actuate freely. Raise the floor pan and lock in upright position. (See Figure 2).

3.1.4 Align the front frame of the mower deck to the FrontRunner tractor lift cylinder section.

3.1.5 Manually lift up on the hitch to get the front frame started.

3.1.6 Push the front frame towards the tractor until the two hitch latches seat into the “secure” position.

3.1.7 Insert the hitch latch retaining pins into the hitch pin lock. The deck is now locked onto the tractor.

3.1.8 Reinstall key and turn switch to the “run” position. Do not start the engine.

3.1.9 Align the cylinder rod end to the top hole of the float link bracket and insert pin as shown in Figure 3. Insert cotter hairpin to lock cylinder pin into place.

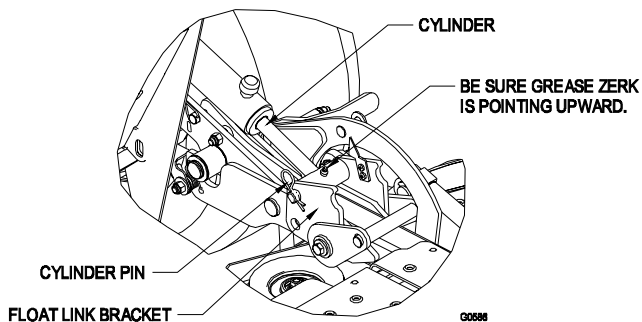

FIGURE 3

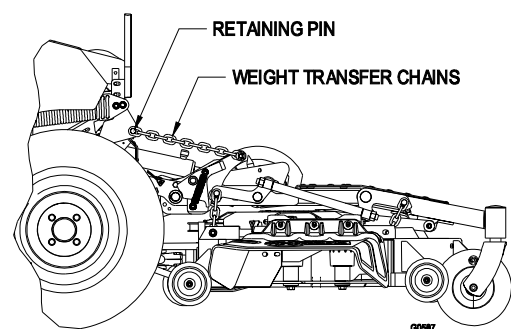

FIGURE 4

3.1.10 Retract the cylinder to fold the deck upward. Reattach weight transfer chains. It is very important not to twist the chains. Lock the chains onto the pin by inserting the cotter hairpin. (See Figure 4)

- 3.1.11 Extend the cylinder fully until the caster wheels contact the ground and deck is in the fully raised position. The fold lock levers should have reset and snapped into the “locked” position. Lower the floor pan.
- 3.1.12 Connect the drive shaft by pushing back the spring loaded collar. Align and couple drive shaft to splined drive shaft and release collar. (See Figure 5)

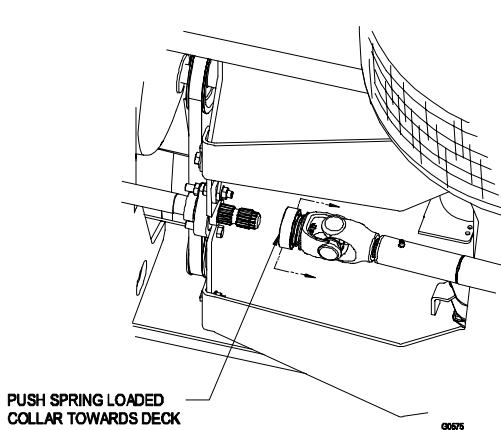

FIGURE 5

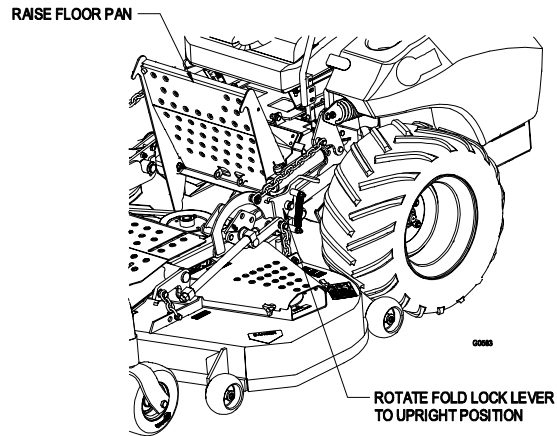

FIGURE 6

3.2 DECK REMOVAL

- 3.2.1 Stop engine, wait for all moving parts to stop, and remove key. Engage parking brake.
- 3.2.2 Disconnect the drive shaft by pulling back on the spring loaded collar and pulling away from the splined shaft (See Figure 5). Lay the drive shaft on the ground.
- 3.2.3 Insert key and turn to the “run” position. Do not start the engine.
- 3.2.4 Extend the cylinder until the fold lock latches are unloaded, and then rotate them toward the tractor.
- 3.2.5 Retract the cylinder and partially fold the deck just to the point where the weight transfer chains go slack.
- 3.2.6 Pull out the hairpins and chain pins from the clevis bracket. Place the pin and cotter hairpin on the chain and set aside.
- 3.2.7 Lower the deck by extending the cylinder until the deck folds down. The caster tires should touch the ground.
- 3.2.8 The float link brackets will start to rotate forward and at this point, the cylinder can be detached at the rod end by pulling the pin out of the bracket. Lift the cylinder out of the way and position the rod end so that it rests on the buckle of the height indicator bracket.
- 3.2.9 Remove the hitch latch pins from the hitch brackets. Raise the hitch latch above the hole and insert pin. The top of the hitch latch should rest under the pin. (See Figure 7)

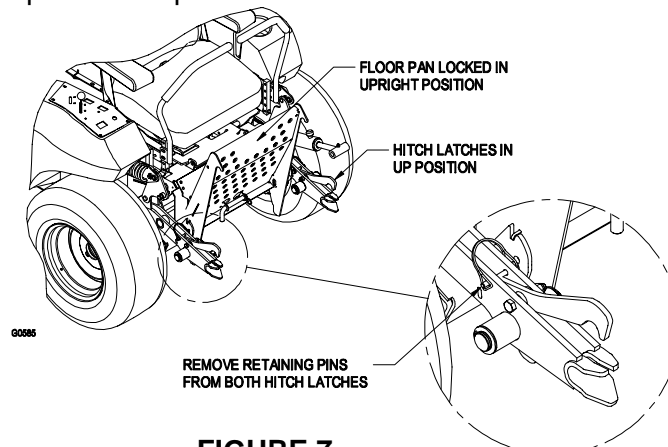



FIGURE 7

3.2.10 Stand in front of the deck and pull the unit away from the tractor or back the tractor away from the deck.

IMPORTANT: Do not transport FrontRunner tractor without an approved Exmark front mount attachment.



4. MAINTENANCE & ADJUSTMENTS

 WARNING 	
POTENTIAL HAZARD <ul style="list-style-type: none">◆ While maintenance or adjustments are being made, someone could start the engine.	
WHAT CAN HAPPEN <ul style="list-style-type: none">◆ Accidental starting of the engine could seriously injure you or other bystanders.	
HOW TO AVOID THE HAZARD <ul style="list-style-type: none">◆ Remove the key from the ignition switch and pull the wire(s) off the spark plug(s) before you do any maintenance. Also push the wire(s) aside so it does not accidentally contact the spark plug(s).	

4.1 DECK RAISING AND LOWERING

4.1.1 Raising the Mower Deck into Service Position:

- a) Stop engine, wait for all moving parts to stop, engage parking brake, and turn key to “run” position. Do not start the engine.

 WARNING 	
POTENTIAL HAZARD <ul style="list-style-type: none">◆ Incorrectly raising or lowering a mower deck can be dangerous.	
WHAT CAN HAPPEN <ul style="list-style-type: none">◆ A dropped mower deck can result in a serious injury or property damage.	
HOW TO AVOID THE HAZARD <ul style="list-style-type: none">◆ Always raise and lower deck on flat, dry ground, free of any obstructions.◆ Always make sure the deck is securely latched in the “up” or “down” position.	

- b) Fully extend the cylinder to unload the fold lock levers.
- c) Rotate the fold lock levers, located on each side of the deck, to the unlocked position. (See Figure 1)
- d) Retract the cylinder and the deck will fold to approximately 50 degrees.

WARNING	
POTENTIAL HAZARD	
◆ Operating the mower in the raised service position can be dangerous.	
WHAT CAN HAPPEN	
◆ Engaging the PTO with a deck in the raised position can result in a serious injury or property damage.	
HOW TO AVOID THE HAZARD	
◆ Always lower and lock mower deck in the operation position before engaging the PTO.	

4.1.2 Raising the Mower Deck into Storage Position:

- a) Stop engine, wait for all moving parts to stop, engage parking brake, and turn key to “run” position. Do not start the engine.
- b) Flip up the floor pan and remove full fold pin. Retract the cylinder to align holes in float link bracket with holes in front frame. (Deck will be at or near lowest height.) Insert into the bottom hole of the float link bracket (see Figure 8). Lower the floor pan.

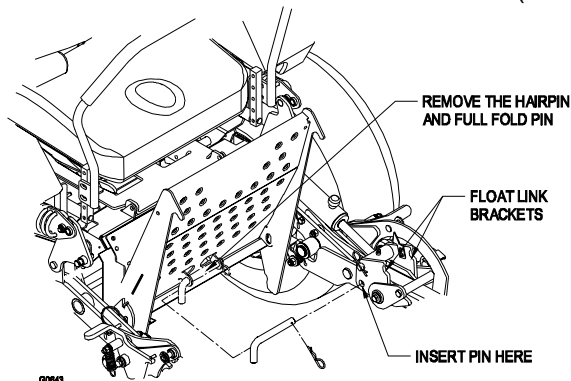



FIGURE 8



WARNING	
POTENTIAL HAZARD	
◆ Folding the mower deck with the floor pan in locked position may be dangerous.	
WHAT CAN HAPPEN	
◆ Hooks will not automatically drop in the slots on the front cover.	
HOW TO AVOID THE HAZARD	
◆ Make sure the floor pan is not locked in the upright position.	

- c) Fully retract cylinder. The deck will fold to an approximate 70 degree angle.

 WARNING 	
POTENTIAL HAZARD	
◆ Driving the mower deck in the folded service position can be dangerous.	
WHAT CAN HAPPEN	
◆ The mower can tip forward.	
HOW TO AVOID THE HAZARD	
◆ Always lower and lock mower deck in the operation position before driving.	

4.1.3 Lowering the Mower Deck to the Operation Position:

- a) Make certain that you and any observers are clear of the deck.
- b) Raise the floor pan to the locked position as shown in Figure 8.
- c) Extend the cylinder until the front caster wheels just touch the ground.
- d) If the full fold pin was used when the deck was folded, remove it from the float link and place it in the storage location under the floor pan.
- e) Fully extend the cylinder until it stops. Confirm that the latches are in the locked position.
- f) Retract the cylinder until the deck lowers to the desired cut height reading shown on the height indicator bar.

 WARNING 	
POTENTIAL HAZARD	
◆ Operating mower without locking latches securely latched can result in the mower deck folding up unexpectedly.	
WHAT CAN HAPPEN	
◆ The mower deck folding up unexpectedly can cause serious injury.	
HOW TO AVOID THE HAZARD	
◆ Always operate mower with locking latches securely latched.	

4.1.4 Cutting Height Adjustment:

- a) Stop engine, wait for all moving parts to stop, engage parking brake, and turn key to “run” position. Do not start the engine.
- b) Adjust cylinder for height of cut desired.

4.2 PERIODIC MAINTENANCE

4.2.1 Clean grass build-up under deck.

Service Interval: Daily

- a) Stop engine, wait for all moving parts to stop, and remove key. Engage parking brake.
- b) Fold mower deck and secure in latched position. See section 4.1.1, Raising the Mower Deck to the Service Position.

- c) Clean out any grass build-up from underside of deck and in discharge chute.
- d) Lower deck to cutting position and lock deck locking pins. See section 4.1.3, Lowering the Mower Deck to the Operation Position.

4.2.2 Check mower blades.

Service Interval: Daily

- a) Stop engine, wait for all moving parts to stop, and remove key. Engage parking brake.
- b) Fold deck and secure in raised position as stated in Section 4.1.1, Raising the Mower Deck to the Service Position.
- c) Inspect blades and sharpen or replace as required.
- d) Reinstall the blades (if they were removed) in the following order (See Figure 9):

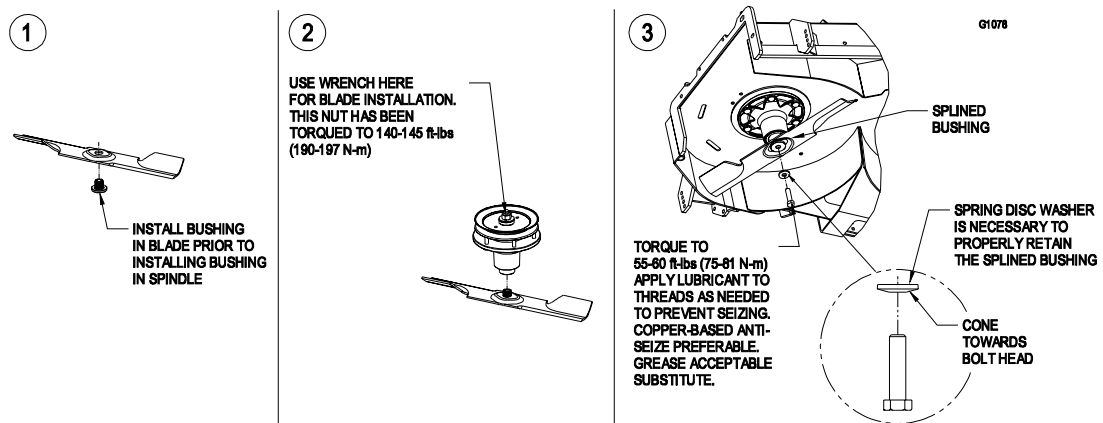

FIGURE 9

- d) Install bushing through blade with bushing flange on bottom (grass) side of blade.
- e) Install bushing/blade assembly into spindle.
- f) Install blade bolt and spring disc washer. Be sure the spring disc washer cone is installed towards the bolt head. Place wrench on the top spindle nut torque the blade bolts to 55-60 ft-lbs. (75-81 N-m).

WARNING
<p>POTENTIAL HAZARD</p> <ul style="list-style-type: none"> ◆ Incorrect installation of the blade or components used to retain the blade can be dangerous.
<p>WHAT CAN HAPPEN</p> <ul style="list-style-type: none"> ◆ Failure to use all original components and assembled as shown could allow a blade or blade component to be thrown out from under the deck resulting in serious personal injury or death.
<p>HOW TO AVOID THE HAZARD</p> <ul style="list-style-type: none"> ◆ Always install the original Exmark blades, blade bushings, spring disc washers, and blade bolts as shown.

- g) Lower the mower deck to the operation position. See section 4.1.3, Lowering the Mower Deck to the Operation Position.

4.2.3 Check for loose hardware:

Service Interval: Daily

- a) Stop engine, wait for all moving parts to stop, and remove key. Engage parking brake.
- b) Visually inspect machine for any loose hardware or any other possible problem. Tighten hardware or correct the problem before operating the unit.

4.2.4 Check tire pressures:

The front caster tires are semi-pneumatic and do not need to be inflated.

NOTE: Do not add any type of tire liner or foam fill material to the tires.

Excessive loads created by foam filled tires may cause failures to the hydro drive system, frame, and other components. Foam filling tires will void the warranty.

4.2.5 Lubricate grease fittings:

Service Interval: Refer to chart.

- a) Stop engine, wait for all moving parts to stop, and remove key. Engage parking brake.
- b) Lubricate fittings with one to two pumps of NGLI grade #2 multi-purpose gun grease.

Refer to the following chart for fitting locations and lubrication schedule.

GREASE FITTING LUBRICATION CHART

FITTING LOCATIONS	INITIAL PUMPS	NO. of PLACES	SERVICE INTERVAL
1. Drive Shaft	1	3	40 hours
2. Deck Flip-Up	1	2	100 hours
3. Front Caster Wheel Hub	1	2	8 hours
4. Caster Pivots	*0	2	*Yearly
5. Height Adj. Shaft Bearings	1	4	40 hours
6. Deck Drive Belt Idler Arm	1	1	Yearly

*See 4.2.5 Section c) for special lubrication instructions on the front caster pivots.

FIGURE 10

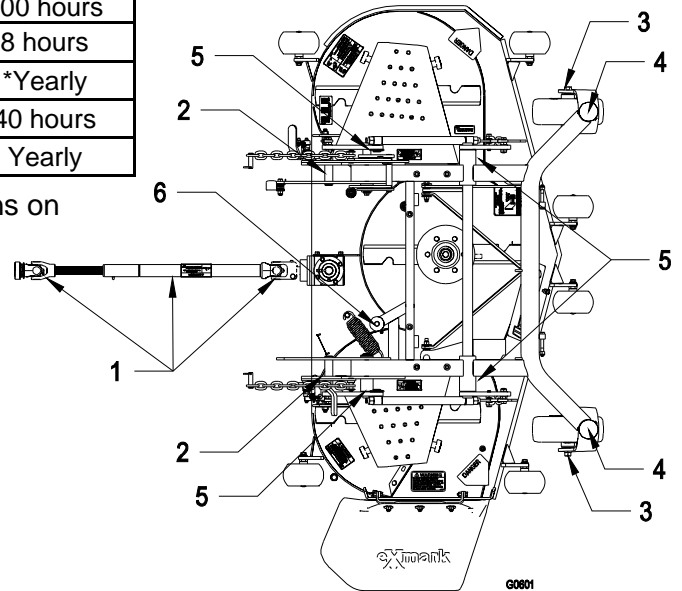

- c) Lubricate front caster pivots once a year. Remove hex plug and cap. Thread grease zerk in hole and pump with grease until it oozes out around top bearing. Remove grease zerk and thread plug back in. Place cap back on.

4.2.6 Change gearbox oil:

Change oil in gearbox housing after first 50 hrs of operation. Check every 100 hours thereafter. Add oil as needed until level with oil drain plug.

- a) Stop engine, wait for all moving parts to stop, and remove key. Engage parking brake.
- b) Place unit on a level surface.

- c) Remove the gearbox and drive shaft assembly from the mower deck. Retain hardware for re-use.
- d) Remove the oil drain plug on the side of the gearbox section and drain oil. (See Figure 11)

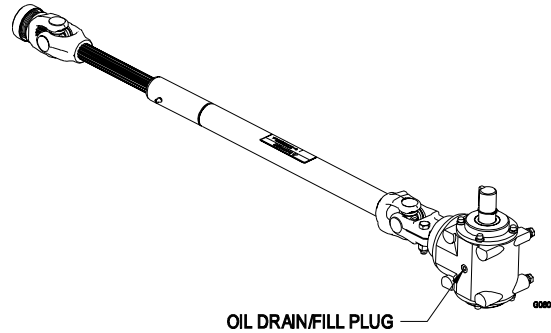

FIGURE 11

- e) Reinstall the gearbox and drive shaft assembly to the mower deck.
- f) Fill gearbox with Mobil SHC (synthetic) 75W-90 gear lube oil until level with oil drain/fill plug. **NOTE:** Mower deck should remain level to the ground when filling gearbox with oil. Do not fill gearbox with deck raised in the service position.
- g) Apply a Teflon pipe sealant to the oil plug and re-install into the gearbox.

4.3 ADJUSTMENTS

IMPORTANT: Disengage PTO, shut off engine, wait for all moving parts to stop, and remove key before servicing, cleaning, or making any adjustments to the unit.

4.3.1 Anti-Scalp Roller Adjustment:

- a) Adjust anti-scalp rollers for Normal Operating Conditions. Place rollers in one of the positions shown in Figure 12. Rollers will maintain 3/4 in. (19 mm) clearance to the ground to minimize gouging and roller wear or damage.

For Maximum Deck Flotation, place rollers one hole position lower. Rollers should maintain 1/4 in. (6.4 mm) clearance to ground. **DO NOT** adjust rollers to support the deck. Be sure roller bolts and nuts are installed with the spring disc washer between head of the bolt and mounting bracket. Torque the 3/8 whizlock nut to 40-45 ft-lbs. (54-61 N-m)

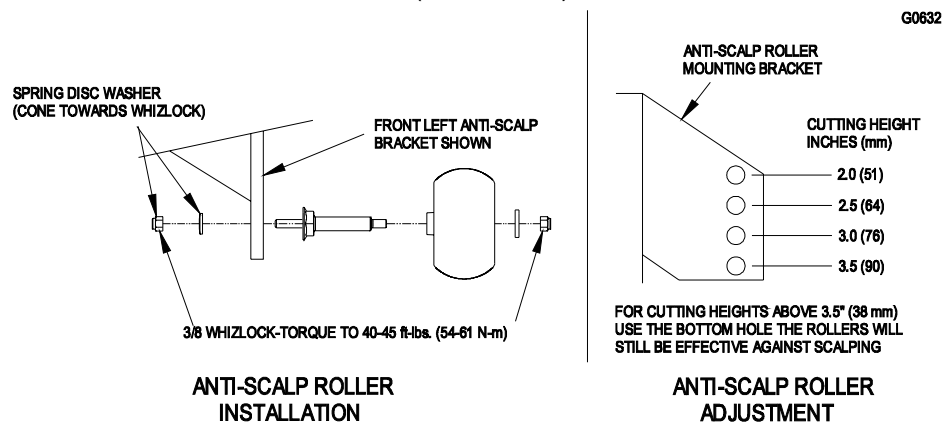

FIGURE 12

- b) When operating in extremely rough conditions it may be necessary to position the anti-scalp rollers one or two holes higher than described in a) to prevent damage to the rollers and/or belt failure.

NOTE: When anti-scalp rollers are placed in these positions, reduced deck flotation will result.

4.3.2 Deck Leveling:

- a) Position mower on a flat surface.
- b) Stop engine, wait for all moving parts to stop. Engage parking brake.
- c) Check tire pressure in drive tires.
For Units Equipped With Turf Tires: The drive tires should be inflated to 13 psi (90 kpa).
For Units Equipped With Bar-Lug Tires: The drive tires should be inflated to 9 psi (62 kpa).
- d) Fully extend the cylinder to raise the deck as high as it will go (this is also the transport position). Note the position of the cut height indicator. Adjust the indicator if necessary so that the indicator is pointing to the 5" cut height mark. See Figure 13.

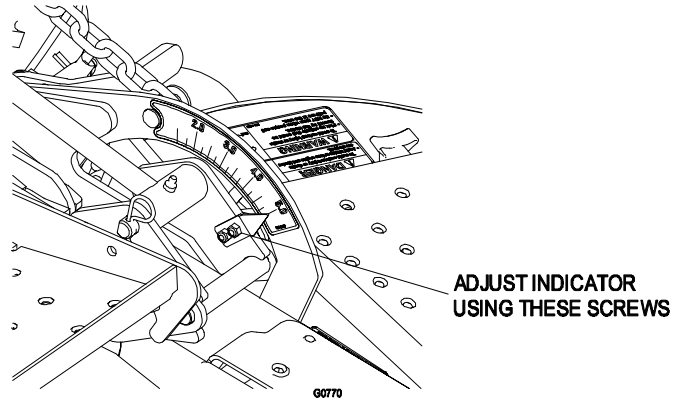

FIGURE 13

- e) Lower the deck to the 4" cut height position and remove ignition key. Orient the blades longitudinally with respect to the machine. Stand a wooden block approximately 5" long next to the front blade tip of the center blade; mark the location of the blade tip on the block. Remove the block and measure height on the block, it should be 4". Repeat this process for the rear blade tip of both the left and right blades, those should measure 4-1/4" to give the recommended 1/4" positive rake. See Figure 14.

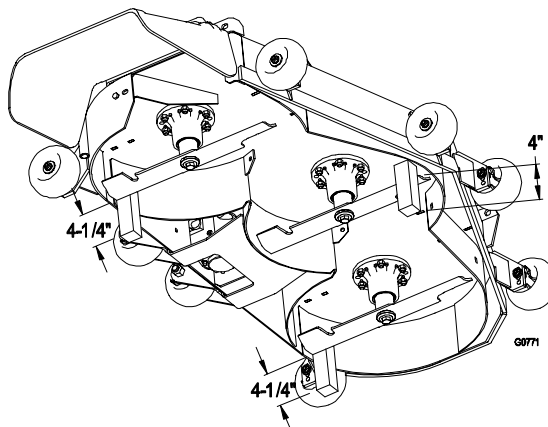

FIGURE 14

- f) If adjustments are necessary, four socket head 5/16-18 x 1-1/4 screws have been provided in the literature bag. Install these screws into the deck lift arms until they touch the hex head deck chain screws. Loosen the top chain screws in slots in the deck lift arms (See Figure 15). Turn the socket head screws to move the deck chain screws up and down to correct the cut heights measured above.

Tighten the chain bolts in the deck lift arms making sure they don't move while tightening.

- g) Recheck the cut heights and that the tension on all the chains is approximately equal. Make sure all chain attachment bolts are tight. Remove the 4 socket head screws and return back to the literature bag.

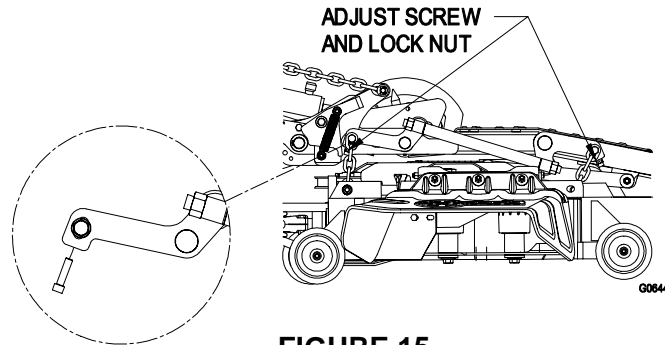

FIGURE 15

4.3.3 Caster pivot bearings pre-load adjustment:

- a) Remove dust cap from caster and tighten nyloc nut until washers are flat. Back the nyloc off 1/4 of a turn to properly set the pre-load on the bearings.

Note: If disassembled, make sure the spring washers are reinstalled as shown in Figure 16.

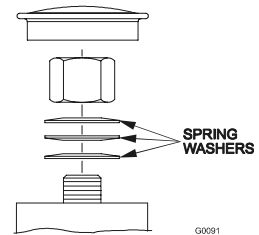

FIGURE 16

5. PARTS LIST

5.1 FR524, FR604, FR724 DECK GROUPS

Item	Part No.	Description	Qty.
1	1-303334	Washer, Spring Disk 5/16	1
2	323-20	Screw, HH 3/8-16 x 3-1/4	1
3	1-322110	Wld, Belt Guide.....	1
4	1-323385	Knob, 3 Prong.....	4
5	1-373034	Washer.....	2
6	98-5975	Washer, Spring Disk 3/8	3
7	32120-10	Ring, Retaining	2
8	1-602913 -01	Wld, Baffle Discharge	1
9	1-603805	Sheave, Idler.....	1
10	1-633109	Sheave, Flat Idler.....	2
11	1-633366	Belt, Blade Drive (52").....	1
	1-633127	Belt, Blade Drive (60").....	1
	1-643052	Belt, Blade Drive (72").....	1
12	109-2985	Strip, Seal, 2"	2
13	103-3900	Spacer, Strut.....	4
14	1-633456	Bushing, Idler.....	2
15	103-2916	Guard, Top.....	1
16	103-3330	Spring, Extension.....	1
17	103-3504	Bearing, Spherical.....	2
18	98-5961	Screw, HH 3/8-16 x 4 Gr8	1
19	103-3505	Seal, Double Lip.....	1
20	103-3506	Seal, Single Lip.....	1
21	103-5677	Spacer	1
22*	103-5693	Asm, Deck Idler	1
23	63-8410	Washer.....	4
24	105-7699	Strip-Seal, 3".....	2
25	106-7159	O-Ring	2
27	302-40	Zerk, 90° 1/4-28	1
28	322-2	Screw, HH 5/16-18 x 5/8	5
29	322-6	Screw, HH 5/16-18 x 1 1/4	1
30	323-12	Screw, HH 3/8-16 x 2 1/2	3

Item	Part No.	Description	Qty.
31	3234-11	Screw, HH FLG 3/8-16 x 1	1
32	3256-24	Washer, 3/8 SAE.....	3
33	3256-3	Washer, 5/16 Std.....	2
34	109-2392	Shield, Belt LH (60")	1
	109-5405	Shield, Belt LH (72")	1
35	109-2391	Shield, Belt RH (60").....	1
	109-5404	Shield, Belt RH (72").....	1
36	32128-20	Nut, Whizlock 5/16-18	6
37	3296-39	Nut, Nyloc 3/8-16	3
38	109-2393	Shield, Belt (52").....	2
39	109-4383	Asm, Deck W/Decals (52")	1
	109-5393	Asm, Deck W/Decals (60")	1
	109-5406	Asm, Deck W/ Decals (72")	1
40	3290-357	Nut, Whizlock 3/8-16	2
41	3256-4	Washer, 3/8 Std.....	2
42	1-633922	Decal, Anti-Scalp	1
43	109-2354	Decal, Crushing Hazard.....	2
44	109-2359	Decal, Deck Warning.....	1
46	109-3148	Decal, Bolt Torque	1
47	1-643222	Decal, Belt Routing.....	1
48	109-2376	Decal, Crushing Hazard.....	1
49	103-8425	Decal, Driveline	1
50	103-1145	Decal, Ultracut (52").....	1
	103-1146	Decal, Ultracut (60").....	1
	103-1147	Decal, Ultracut (72").....	1
51	1-403005	Danger, Decal.....	2
52	1-303508	Decal, Discharge Warning	1
53	98-5954	Decal-Danger	3
54♦	109-4382	Asm, Deck Complete (52")	1
	109-4380	Asm, Deck Complete (60")	1
	109-5419	Asm, Deck Complete (72")	1

Exmark red touch up paint (spray paint - P/N 1-850337 - .6 oz liquid bottle - P/N 103-9140).

* Kit also includes items #37 & #53.

♦ Complete deck assembly includes all items from pages 15 & 17 except drive shaft assembly, drive shaft assembly hardware, deck chain, and deck chain hardware on page 16.

5.1 FR524, FR604, FR724 DECK GROUPS (cont.)

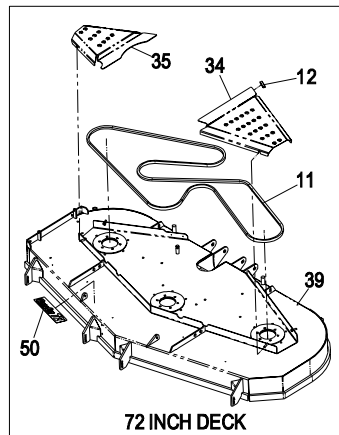
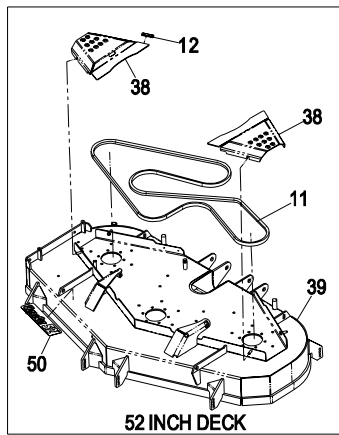
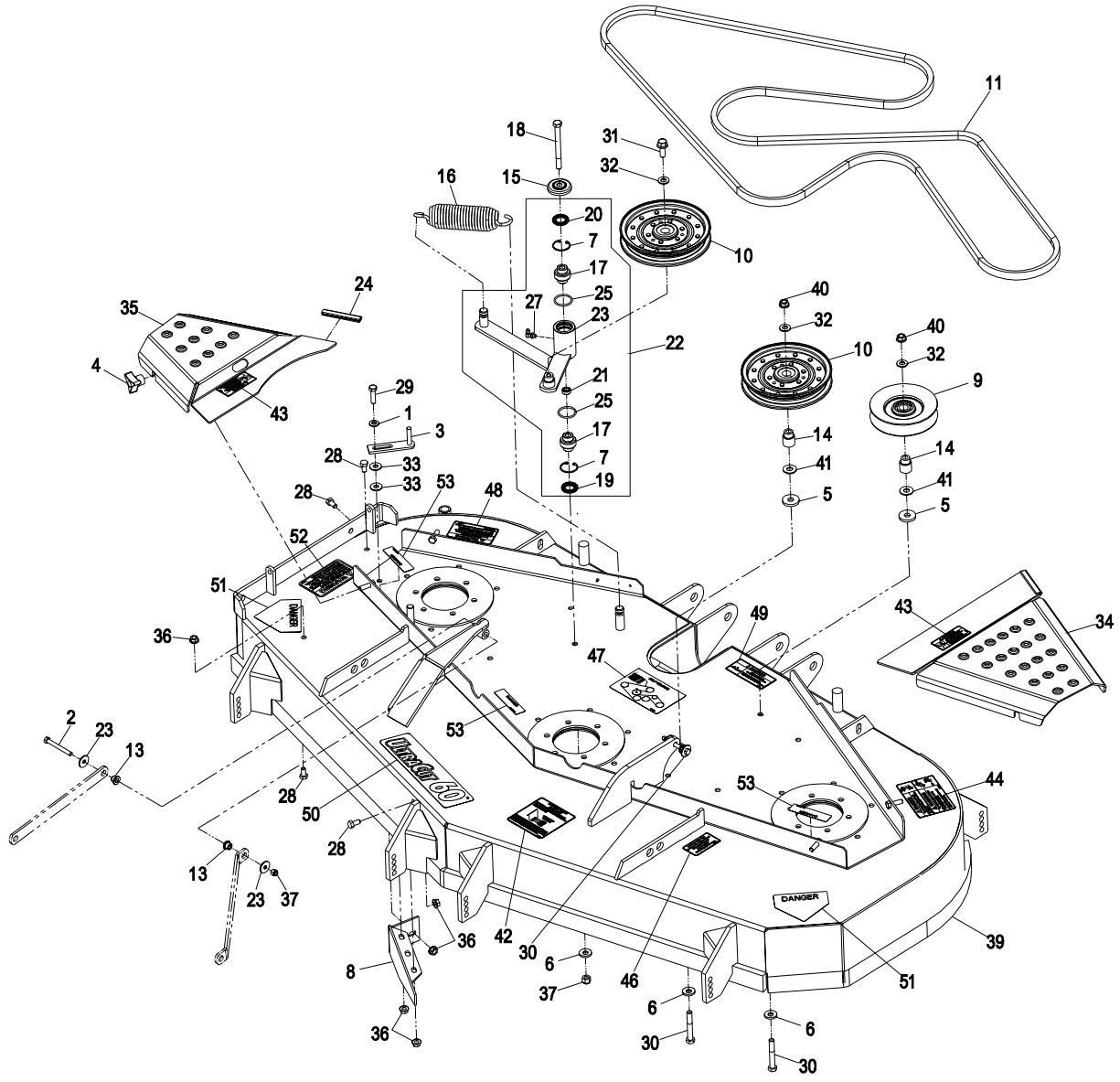

G0994

5.1 FR524, FR604, FR724 DECK GROUPS (cont.)

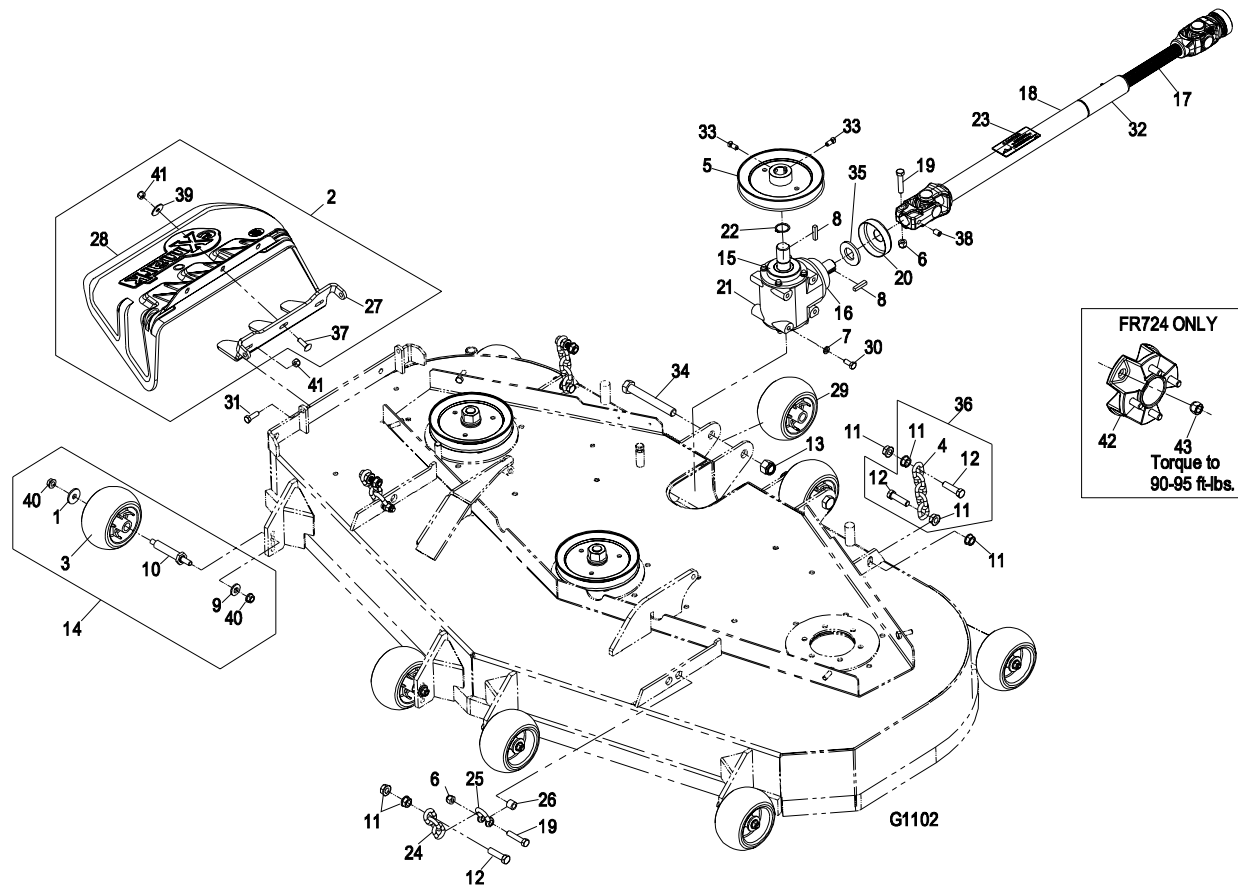

Item	Part No.	Description	Qty.
1	63-8410	Washer	6
2	109-2148	Asm, Discharge Chute	1
3	1-603299	Roller, Anti Scalp	6
4	1-633447	Chain, Deck Lift	2
5	109-2714	Sheave, Split Steel (52")	1
	1-643292	Sheave, Split Steel (60" & 72")	1
6	3296-39	Nut, Nyloc 3/8-16	3
7	1-805005	Washer, Lock 5/16 Heavy	4
8	13-2840	Key, Machine 1/4 x 1/4 x 1 1/4	2
9	98-5975	Washer, Spring Disk 3/8	6
10	99-2842	Spacer-Wheel	6
11	32128-37	Nut, Whizlock 7/16-14	12
12	103-1898	Screw, HH 7/16-20 x 1-5/8 Sp	6
13	3296-53	Nut, Nyloc 5/8-11	2
14	103-4051	Kit, Anti-scalp	6
15	100-4576	Seal, 1-1/2 X 1 X 1/4	1
16	100-4575	Seal, 2 X 1 X 1/4	1
17	109-4449	Driveshaft, Fr Splined Half	1
18	109-4448	Asm, Driveshaft Tube W/Decal	1
19	323-9	Screw, HH 3/8-16 x 1 3/4	3
20	109-4941	Guard, Seal	1
21	103-7959	Gearbox	1

Item	Part No.	Description	Qty.
22	32151-29	Ring, Retaining	1
23	103-8425	Decal, Driveline	1
24	103-9859	Chain, Decklift Front	2
25	103-9861	Shackle, Front Chain	2
26	103-9863	Bushing Shackle	2
27	109-0938-01	Bracket, Discharge Chute	1
28	109-2738	Chute, Discharge	1
29	109-2965	Roller, Full Hub	2
30	322-3	Screw, HH 5/16-18 x 3/4	4
31	322-5	Screw, HH 5/16-18 x 1	2
32	109-2767	Asm, Driveshaft	1
33	1-803022	Setscrew, 5/16-18 x 5/8	2
34	327-12	Screw, HH 5/8-11 x 4 3/4	2
35	109-4492	Washer, Special	1
36	103-9792	Asm, Chain Deck	2
37	3230-22	Bolt, Carriage 5/16-18 x 1 Sp	3
38	3247-4	Setscrew, HSH 3/8-16 x 5/8	1
39	3256-82	Washer	3
40	3290-357	Nut, Whizlock 3/8-16	12
41	3296-29	Nut, Nyloc 5/16-18	5
42	109-6207	Asm, Wheel Spacer	2
43	242-50	Nut, Lug	8

Exmark red touch up paint (spray paint - P/N 1-850337 - .6 oz liquid bottle - P/N 103-9140).

● Use Pro-Lock, Nut Type (P/N 1-840022, .5ml tube) on setscrew, item #38.

5.2 SPINDLE ASSEMBLY

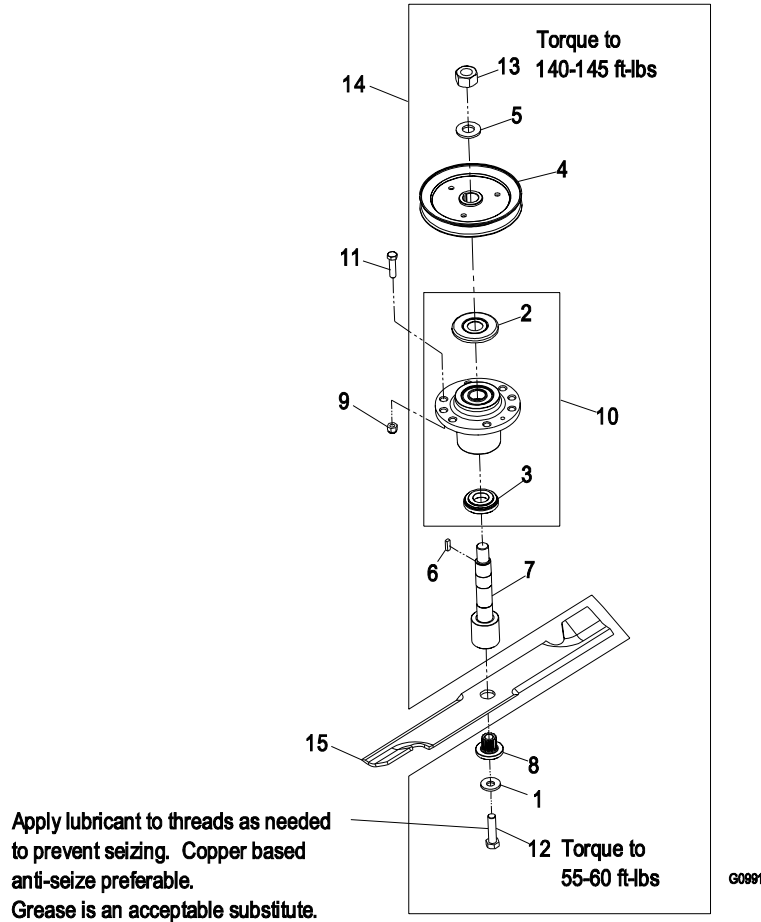

Item	Part No.	Description	Qty.
1	1-513435	Washer, Spring Disk 1/2	3
2+	103-1330	Guard, Bearing Top	3
3	103-2535	Spacer, Guard Bottom	3
4+	103-2794	Sheave, Blade Drive (52" & 60").....	3
	103-2795	Sheave, Blade Drive (72").....	3
5	103-2802	Washer, Spring Disk 3/4	3
6	103-2982	Key, Machine 1/4 x 3/16 x 3/4	3
7□+	103-9086	Kit, Spindle	3
8	103-3037	Bushing, Splined	3
9	3296-39	Nut, Nyloc 3/8-16	21
10	103-8280	Asm, Cutter Housing.....	3
11	323-8	Screw, HH 3/8-16 x 1 1/2	18
	323-7	Screw, HH 3/8-16 x 1 1/4	18
12	3213-5	Screw, HH 1/2-20 x 2	3
13●	3217-46	Nut, Hex 3/4-16 Heavy	3
14	103-9076	Asm, Cutter Housing Complete (52" & 60")..	3
	103-9074	Asm, Cutter Housing Complete (72")	3

Item	Part No.	Description	Qty.
15	103-6402	Blade, Notched (52").....	3
	103-6387	Blade, Low Lift (52").....	3
	103-6382	Blade, Solid (52").....	3
	103-6397	Blade, Extreme (52").....	3
◆	103-6392	Blade, Mulching (52").....	3
	103-6403	Blade, Notched (60").....	3
	103-6388	Blade, Low Lift (60").....	3
	103-6383	Blade, Solid (60").....	3
	103-6398	Blade, Extreme (60").....	3
◆	103-6393	Blade, Mulching (60").....	3
	103-6404	Blade, Notched (72").....	3
	103-6389	Blade, Low Lift (72").....	3
	103-6384	Blade, Solid (72").....	3
	103-6399	Blade, Extreme (72").....	3
◆	103-6394	Blade, Mulching (72").....	3

- ◆ Requires installation of Micro-Mulch accessory for proper mulching. Mulch kit P/N MK524Q (52"), MK604Q (60") and MK724
- Kit includes items #1, #5, #6, #8, #12 & #13.
- + Apply Mobil HTS grease (P/N 103-5217 1.5 oz packet) (or a food-grade anti-seize) between the spindles & bearings and spindles & sheaves and under top bearing guard. DO NOT use a copper or nickel based anti-seize.
- Use Pro-Lock, Nut Type (P/N 1-840022, .5ml tube) on nut, Item #13.

5.3 FRONT FRAME GROUP

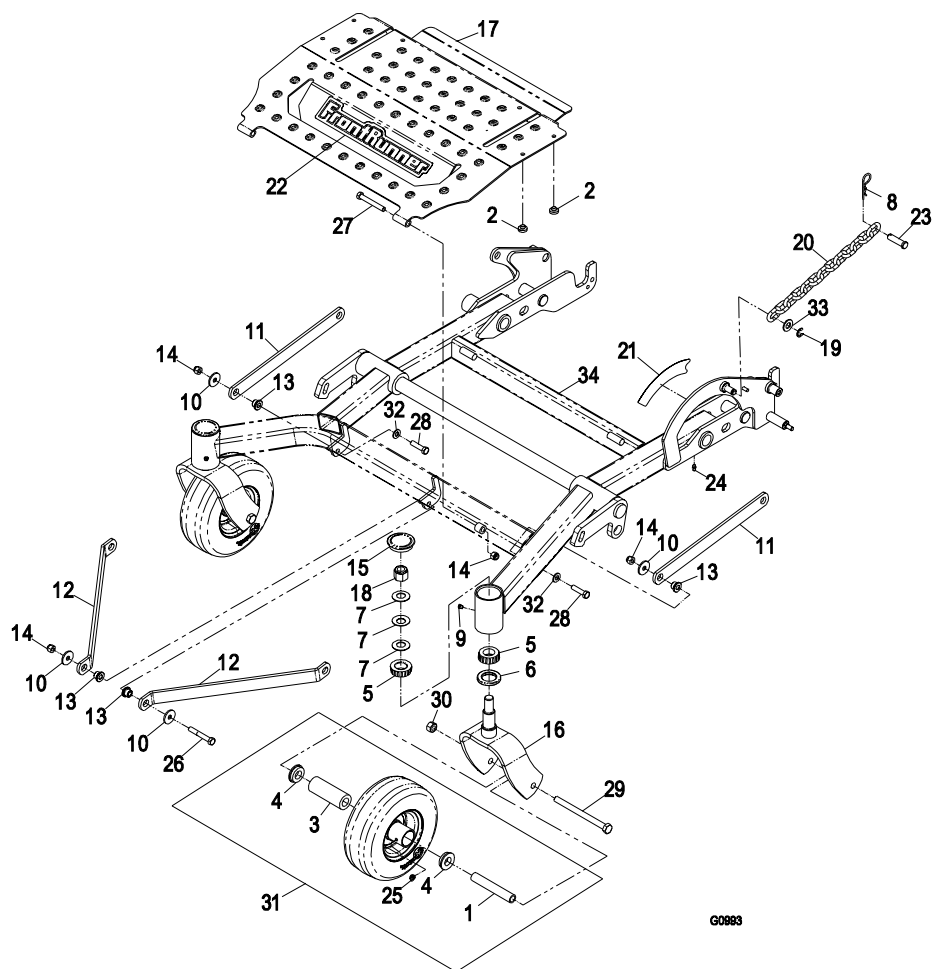
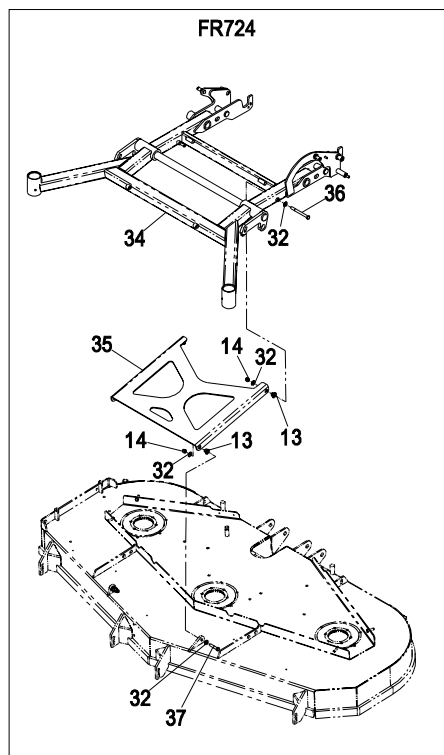

Item	Part No.	Description	Qty.
1	1-513547	Spacer, Front Caster.....	2
2	1-513658	Bumper.....	6
3	1-513809	Bearing, Roller.....	2
4	1-513810	Bushing, Flanged.....	4
5	1-543509	Cone, Bearing Tapered Roller.....	4
6	1-543511	Seal, Grease.....	2
7	1-633508	Washer, Spring Disk.....	6
8	1-806005	Hairpin, Cotter.....	2
9	1-811010	Plug.....	2
10	63-8410	Washer.....	4
11	103-3898	Flat, Strut.....	2
12	103-3899	Flat, Strut Angle.....	2
13	103-3900	Spacer, Strut.....	4
14	3296-39	Nut, Nyloc 3/8-16 (52" & 60").....	5
	3296-39	Nut, Nyloc 3/8-16 (72").....	11
15	103-4882	Cap, Grease.....	2
16	103-9712-01	Wld, Caster Fork.....	2
17	109-2379	Asm, Front Cover W/Decal.....	1
18	3296-51	Nut, Nyloc 3/4-10.....	2
19	32120-47	Ring, Retaining.....	2

Item	Part No.	Description	Qty.
20	109-0636	Chain, Weight Transfer.....	2
21	109-2993	Decal, Cutting Height.....	1
22	109-2114	Decal, FrontRunner.....	1
23	283-40	Pin, Clevis 1/2 x 1 3/4.....	2
24	302-19	Zerk, 1/4-28 Str.....	4
25	302-61	Zerk, 45° 1/4-28.....	2
26	323-12	Screw, HH 3/8-16 x 2 1/2.....	1
27	323-13	Screw, HH 3/8-16 x 2 3/4.....	2
28	323-8	Screw, HH 3/8-16 x 1 1/2.....	2
29	325-20	Screw, HH 1/2-13 x 6.....	2
30	3296-45	Nut, Hex 1/2-13.....	2
31	103-2171	Kit, Tire & Wheel Asm W/ Spacer.....	2
32	3256-24	Washer, 3/8 SAE.....	2
33	3256-26	Washer, 1/2 SAE.....	2
34	109-4574	Asm, Front Frame W/Decal FR524.....	1
	109-4575	Asm, Front Frame W/Decal FR604.....	1
	109-5408	Asm, Front Frame W/Decal FR724.....	1
35	109-4455-01	Strut, Deck FR724.....	1
36	323-16	Screw, HH 3/8-16 x 4.....	2
37	323-9	Screw, HH 3/8-16 x 1 3/4.....	2

Exmark red touch up paint (spray paint - P/N 1-850337 - .6 oz liquid bottle - P/N 103-9140).

5.3 FRONT FRAME GROUP (cont.)

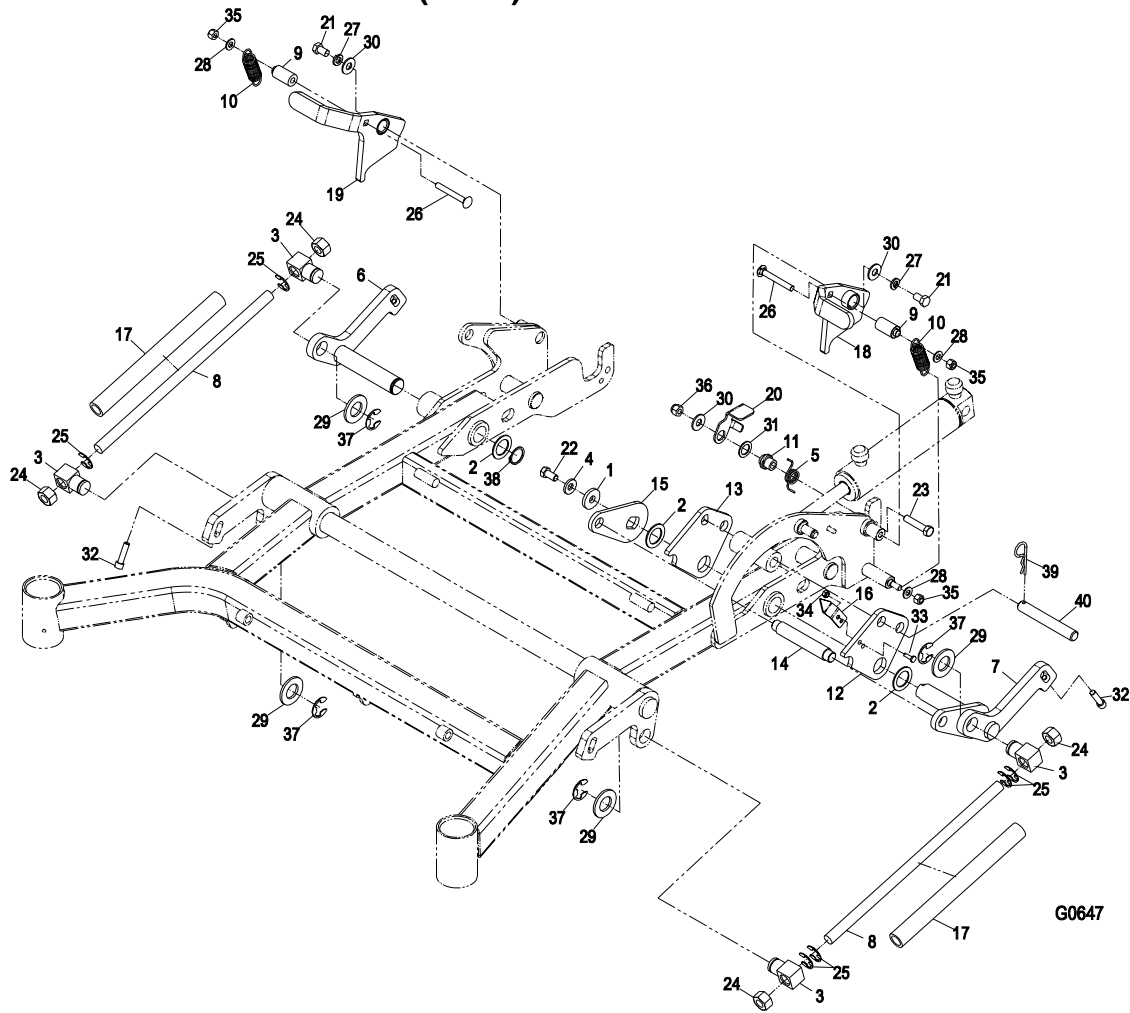

Item	Part No.	Description	Qty.
1	1-373034	Washer	1
2	1-523157	Washer	3
3	1-633441	Swivel, Deck Mount Rear	4
4	98-5975	Washer, Spring Disk 3/8	1
5	103-8316	Spring, Torsion	1
6	103-9699-01	Wld, Decklift Arm	1
7	103-9708-01	Wld, Decklift Arm	1
8	103-9710	Rod, Decklift	2
9	103-9714	Spacer, Spring Anchor	2
10	105-1210	Spring-Extension	2
11	107-0075	Bushing	1
12	109-3013-01	Plate, Cylinder Mount	1
13	109-3014-01	Plate, Cylinder Mount	1
14	109-0047	Pin, Decklift Stop	1
15	109-0340-01	Arm, Deck Lift	1
16	109-1896	Arm, Height Indicator	1
17	109-2065	Tube, Decklift Rod	2
18	109-2205	Wld, Lock Lever LH	1
19	109-2206	Wld, Lock Lever RH	1
20	109-2760	Arm, PTO Switch	1

Item	Part No.	Description	Qty.
21	323-34	Screw, HH 3/8-16 x 5/8	2
22	323-4	Screw, HH 3/8-16 x 3/4	1
23	323-9	Screw, HH 3/8-16 x 1 3/4	1
24	3217-11	Nut, Hex 5/8-11	4
25	32151-48	E-Ring	6
26	3230-8	Bolt, Carriage 5/16-18 x 2 1/2	2
27	3253-5	Washer, Lock 3/8	2
28	3256-23	Washer, 5/16 SAE	4
29	3256-29	Washer, 7/8 SAE	4
30	3256-4	Washer, 3/8 Std	3
31	3256-69	Washer-Flat	1
32	3274-18	Screw, SH 5/16-18 x 1 1/4	4
33	3290-500	Screw, PPH #10-24 x 5/8	2
34	3296-2	Nut, Nyloc #10-24	2
35	3296-29	Nut, Nyloc 5/16-18	4
36	3296-39	Nut, Nyloc 3/8-16	1
37	32151-103	E-Ring	4
38	32151-29	Ring, Retaining	1
39	1-806005	Hairpin, Cotter	1
40	109-0045	Pin, Cylinder Mount	1

Exmark red touch up paint (spray paint - P/N 1-850337 - .6 oz liquid bottle - P/N 103-9140).

5.4 DECAL GROUP

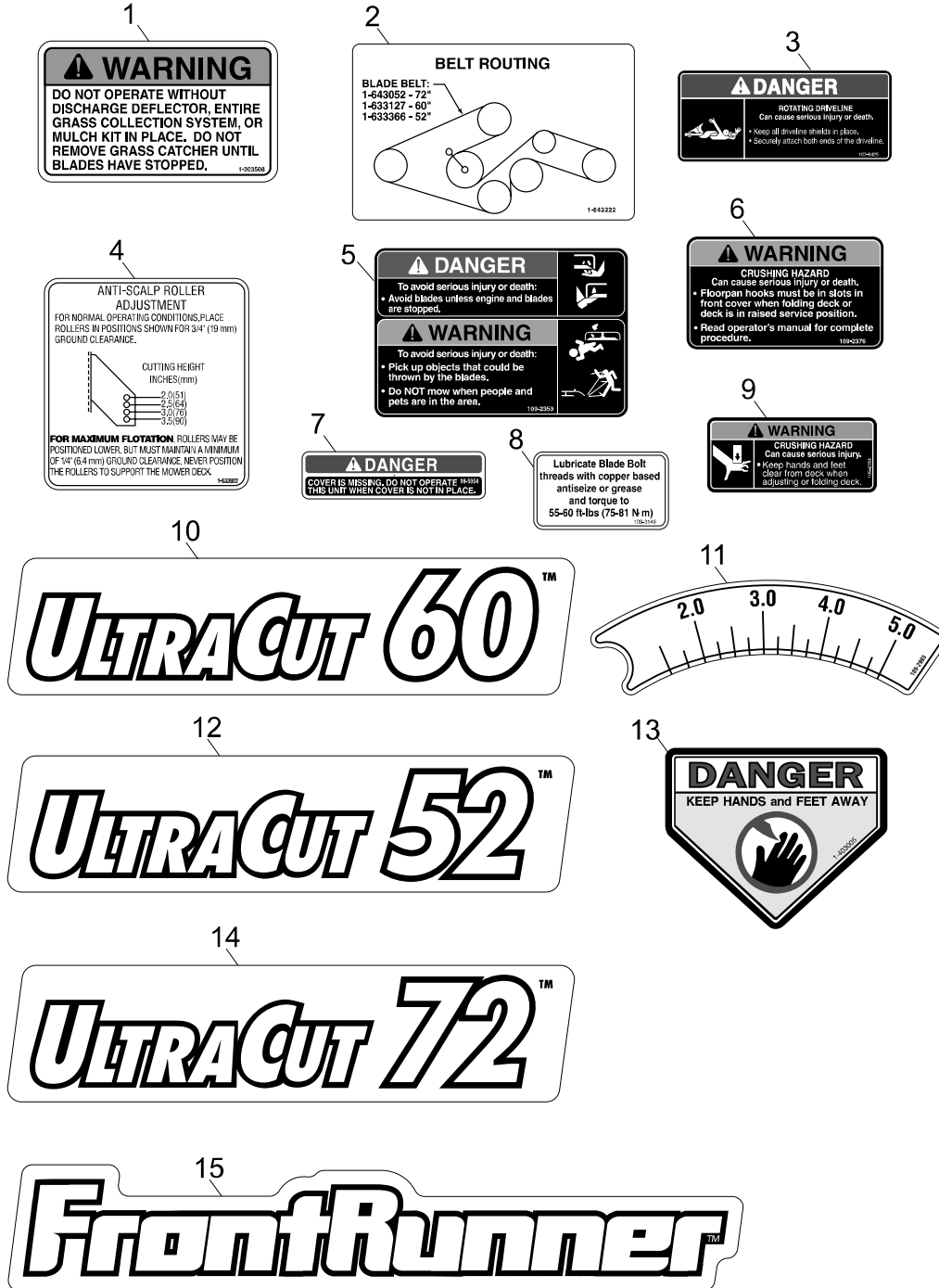

Item	Part No.	Description	Qty.
1	1-303508	Decal, Discharge Warning	1
2	1-643222	Decal, Belt Routing	1
3	103-8425	Decal, Driveline.....	2
4	1-633922	Decal, Antiscalp.....	1
5	109-2359	Decal, Deck Warning	1
6	109-2376	Decal, Crushing Hazard	1
7	98-5954	Decal, Missing Cover	3
8	109-3148	Decal, Bolt Torque	1

Item	Part No.	Description	Qty.
9	109-2354	Decal, Crushing Hazard.....	2
10	103-1146	Decal, Ultracut 60	1
11	109-2993	Decal, Deck Height.....	1
12	103-1145	Decal, Ultracut 52	1
13	1-403005	Decal, Danger.....	2
14	103-1147	Decal, Ultracut 72	1
15	109-2114	Decal, FrontRunner	1
	109-3062	Decal Kit	

6.

**2-Year Limited Warranty
Exmark Turf Equipment**

(For units purchased on or after October 1, 2004)

Conditions and Products Covered

Exmark Mfg. Co. Inc. and its affiliate, Exmark Warranty Company, pursuant to an agreement between them, jointly warrant on the terms and conditions herein, that we will repair, replace or adjust any part manufactured by Exmark and found by us (in the exercise of our reasonable discretion) to be defective in factory materials or workmanship for a period of two years.

This warranty applies to Exmark turf equipment purchased on or after October 1, 2004 sold in the US or Canada. This warranty may only be assigned or transferred to a second (or third) owner by an authorized Exmark dealer. The warranty period commences upon the date of the original retail purchase.

<u>Products</u>	<u>Warranty Period</u>
• All Products (except as noted below)	2 years
• All Attachments and Accessories	1 year
• Metro 21 and Metro 26 Series	1 year
• Belts and Tires	90 days
• Battery	1 Year Prorated
• Engine*	Warranty is covered by engine manufacturer

*Please refer to the engine manufacturer's warranty statement that is included in the literature packet. We are not authorized to handle warranty adjustments on engines.

This warranty only includes the cost of parts and labor.

Items and Conditions Not Covered

This warranty does not cover the following:

- Pickup and delivery charges to and from any authorized Exmark Service Dealer.
- Any damage or deterioration due to normal use, wear and tear, or exposure.
- Cost of regular maintenance service or parts, such as filters, fuel, lubricants, tune-up parts, and adjustments.
- Any product or part which has been altered or misused or required replacement or repair due to normal wear, accidents, or lack of proper maintenance.
- Any repairs necessary due to use of parts, accessories or supplies, including gasoline, oil or lubricants, incompatible with the turf equipment or other than as recommended in the operator's manual or other operational instructions provided by Exmark.

All warranty work must be performed by an authorized Exmark Service Dealer using Exmark approved replacement parts.

Instructions for Obtaining Warranty Service

1. Contact any Exmark Service Dealer to arrange service at their dealership. To locate a dealer convenient to you, access our website at www.exmark.com. U.S. Customers may also call 402-223-6375.
2. Bring the product and your proof of purchase (sales receipt) to the Exmark Service Dealer.

If for any reason you are dissatisfied with the Service Dealer's analysis or with the assistance provided, contact us at:

Exmark Customer Service Department
 The Exmark Warranty Company
 2101 Ashland Avenue
 Beatrice, NE 68310
 402-223-6375 or
service@exmark.com

Owner's Responsibilities

The Exmark turf equipment, including any defective part, must be returned to an authorized Exmark service dealer within the warranty period. This warranty extends only to turf equipment operated under normal conditions. You must properly service and maintain your Exmark product as described in the operator's manual. Such routine maintenance, whether performed by a dealer or by you, is at your expense.

As a condition to this warranty, customer shall have read the operator's manual and shall have completed and submitted to Exmark Warranty Company, within the prescribed time, the Exmark warranty registration.

General Conditions

The sole liability of Exmark and Exmark Warranty Company with respect to this warranty shall be repair and replacement as set forth herein. **Neither Exmark nor Exmark Warranty Company shall have any liability for any other cost, loss or damage, including but not limited to, any incidental or consequential loss or damage.**

In particular, we shall have no liability or responsibility for:

- Expenses related to gasoline, oil or lubricants.
- Travel time, overtime, after hours time or other extraordinary repair charges or charge relating to repairs or replacements outside of normal business hours at the place of business of the authorized Exmark service dealer.
- Rental of like or similar replacement equipment during the period of any warranty, repair or replacement work.
- Any telephone or telegram charges or travel charges.
- Loss or damage to person or property other than that covered by the terms of this warranty.
- Any claims for lost revenue, lost profit or additional cost as a result of a claim of breach of warranty.
- Attorney's fees.

No Claim of breach of warranty shall be cause for cancellation or rescission of the contract of sale of any Exmark mower.

There are no understandings, agreements, representations, or warranties, express or implied, including but not limited to any regarding the merchantability (that product is fit for ordinary use) or fitness for use (that product is fit for a particular purpose), not specified herein, respecting the equipment which is the subject of this warranty.

Some states do not allow exclusions of incidental or consequential damages, or limitations on how long an implied warranty lasts, so the above exclusions and limitations may not apply to you.

This warranty gives you specific legal rights, and you may also have other rights which vary from state to state.

SEE EXMARK'S COMPLETE LINE OF ACCESSORIES

RIDING ACCESSORIES

CUSTOM RIDE SEAT SUSPENSION SYSTEM
DECK LIFT ASSIST KIT
HITCH KIT
LIGHT KIT
MICRO-MULCH SYSTEM
ROLL OVER PROTECTION SYSTEM (ROPS)
SNOW BLADE
SUN SHADE
TRASH CONTAINER
TURF STRIPER
ULTRA VAC COLLECTION SYSTEM
ULTRA VAC QUICK DISPOSAL SYSTEM

WALK BEHIND ACCESSORIES

GRASS CATCHER
MICRO-MULCH SYSTEM
STEERABLE SULKY
SULKY HITCH KIT
TURF STRIPER
STANDON

Check us out on the Web:

www.exmark.com

© 2005-2006 EXMARK MFG. CO. INC.
INDUSTRIAL PARK BOX 808
BEATRICE, NE 68310

PART NO. 109-6531 Rev. A
(402) 223-6300
FAX (402) 223-5489

ALL RIGHTS RESERVED

PRINTED IN U.S.A.

