

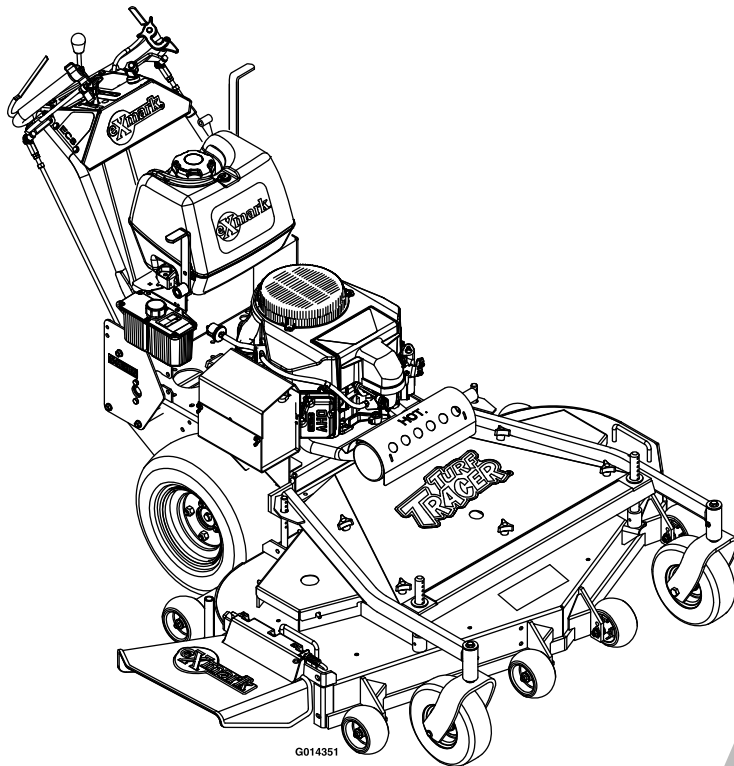

TURF TRACER® S-SERIES

Model No. TTS16KA483—Serial No. 920000 and Up

Picture below may not reflect actual product.



Parts Manual

Part No. 4500-772 Rev. B

Ordering Replacement Parts

To order replacement parts, please supply the part number, the quantity, and the description of each part desired.

Understanding Reference Numbers

Each identified part in an illustration has a reference number. The reference number for a part also appears in the parts list, along with other information about the part.

This catalog uses two special reference number formats, one to indicate parts in a service assembly and another to indicate the quantity of a given part in an illustration.

Service Assembly Reference Numbers

Parts in service assemblies have reference numbers in the form a:b. The a represents the reference number of the entire service assembly and the b represents a sequential number unique to each part within the service assembly.

For example, a wheel assembly might be identified by reference number 6, the tire by 6:1, the valve by 6:2, and the wheel by 6:3. When you order the assembly identified by reference number 6, you receive all parts identified by reference numbers 6:1, 6:2, and 6:3. However, you may also order any part individually. Reference numbers of this type appear in illustration and in parts lists.

Reference Numbers Indicating Quantity

In an illustration, if a reference number indicates more than one part, the reference number has the form nX y. The n represents the quantity of the part, the X is the multiplication symbol, and the y represents the reference number.

For example, in an illustration, the reference number 2X 37 means that two of the parts identified by reference number 37 are indicated.

List of Abbreviations

AR: as required	HOC: height-of-cut	RRB: rear roller brush
ASM: assembly	HSBH: hex socket button head	SFH: slotted fillister head
BBC: blade brake control	HSFH: hex socket flat head	SHH: slotted hex head
BHTF: button head thread forming	HSH: hex socket head	SHWH: slotted hex washer head
CARR: carriage	HWH: hex washer head	SPH: slotted pan head
CCW: counter clockwise	HWTF: hex washer head thread forming	SQH: square head
CW: clockwise	HYD: hydraulic	SRH: slotted round head
DEG: degrees	LH: left hand	STD: standard
DPA: Dual Point Adjustment	LP: Liquid Propane	TAP: self tapping
ECM: electronic control module	NI: nylon insert	TTH: torx truss head
EXT: external	NPTF: national pipe thread fine	
FH: flat head	PFH: phillips flat head	
GA: gauge	PPH: phillips pan head	
HD: heavy-duty	PPHTF: phillips pan head thread forming	
HF: hex flange	PRH: phillips round head	
HH: hex head	PTH: phillips truss head	
HHF: hex head flange	PTO: power-take-off	
HHFTF: hex head flange thread forming	RH: right hand	
HJ: hex jam	ROPS: roll-over protection system	
HLH: hex lag head		

Touch Up Paint

Exmark black touch up spray paint – gloss black.

Exmark red touch up paint (spray paint – P/N 1-850337 - .6 oz liquid bottle – P/N 103-9140).

EXMARK PARTS PLUS

PARTS

OVERNIGHT

OR *FREE**

If your Exmark dealer does not have the Exmark part in stock, Exmark will get the parts to the dealer the next business day or the part will be FREE Guaranteed!! (Some restrictions apply. See your participating Exmark Dealer for details.)

Contents

Mower Deck Assembly	6
Engine Deck Assembly	8
Engine Deck Assembly (cont.)	10
ECS Upper Handles and Controls Assembly	12
Fuel Tank Assembly	14
Electrical Assembly	15
Hydraulic Assembly	16
Decals	18

Mower Deck Assembly

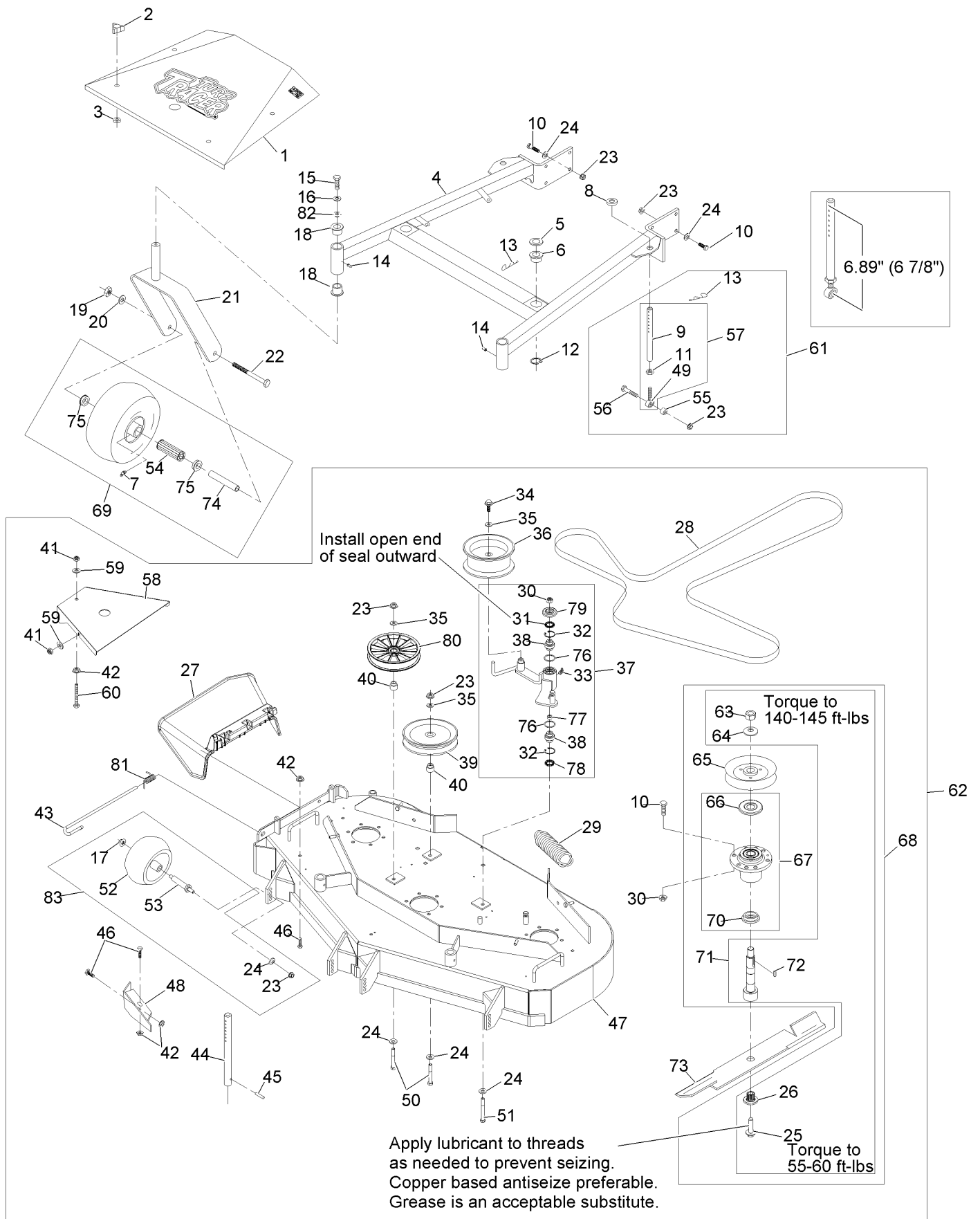

Mower Deck Assembly (continued)

<i>Ref.</i>	<i>Part Number</i>	<i>Qty.</i>	<i>Description</i>	<i>Ref.</i>	<i>Part Number</i>	<i>Qty.</i>	<i>Description</i>
1	116-2711	1	Shield, Belt (1-413101-01) W/Decals	47	1-414384	1	Wld, Deck (116-2457-01) W/Decals, Discharge Baffle & Support Rods
2	1-323385	4	Knob-3 Prong	48	116-2297-01	1	Baffle, Discharge
3	1-323417	4	Washer-Belt Shield	49	1-613204	2	Balljoint
4	1-414310	1	Wld, Support (1-412110-01) W/Bushings & Decals	50	323-13	2	Screw-HH 3/8-16 X 2 3/4
5	1-413425	2	Spacer	51	98-5961	1	Screw-HH 3/8-16 X 4 Gr8
6	1-513336	2	Bushing-Deck	52	1-603299	4	Roller-Scalp, Anti
7	302-61	2	Zerk-45° 1/4-28	53	99-2842	4	Spacer
8	1-323539	2	Spacer-Blade Drive	54	1-513809	2	Bearing
9	1-413525	2	Link, Rear Deck Support	55	1-603050	2	Spacer
10	323-7	26	Screw-HH 3/8-16 X 1 1/4	56	323-9	2	Screw-HH 3/8-16 X 1 3/4
11	3220-3	2	Nut-Jam 3/8-24	57	1-414521	2	Link, Assembly
12	32120-33	2	Ring-Retaining	58	103-2970-01	2	Shield, Belt
13	1-806009	4	Hairpin-Cotter #206	59	3256-3	6	Washer-5/16 Std
14	302-52	2	Zerk-1/8-27 Str	60	1-800017	2	Bolt-HH 5/16-18 X 3 1/4 Tap
15	323-6	2	Screw-HH 3/8-16 X 1	61	1-411532	2	Kit, Support Link W/Pin
16	3253-5	2	Washer-Lock 3/8 Heavy	62	103-0321	1	Asm, Deck Complete
17	109-6658	4	Nut-Nyloc 3/8-16 Flg	63	3217-46	3	Nut-Hex 3/4-16 Heavy
18	1-303514	4	Bearing-Flanged	64	103-2802	3	Washer-Spring Disc 3/4
19	3217-9	2	Nut-Hex 1/2-13	65	1-413424	3	Sheave W/ Hub ▲
20	3253-7	2	Washer-Lock 1/2	66	103-1330	3	Guard-Bearing Top ▲
21	1-522143-01	2	Wld, Caster	67	103-8280	3	Kit, Cutter Housing
22	325-20	2	Screw-HH 1/2-13 X 6	68	103-9081	3	Asm, Cutter Housing Complete
23	3290-357	13	Nut-Whizlock 3/8-16	69	103-2171	2	Kit, Tire & Wheel Asm W/ Spacer
24	98-5975	15	Washer-Spring Disc 3/8	70	103-2535	3	Spacer-Guard Bottom
25	109-9220	3	Screw-Sems 1/2-20 X 2.19	71	103-9071	3	Kit, Spindle ▲
26	103-3037	3	Bushing,Splined	72	1-807268	3	Key-Machine 1/4 X 3/16 X 1
27	109-5151	1	Cht Disch Xrk M056	73	103-6401	3	Blade-Notched ■
28	1-413093	1	Belt - V, B	73	103-6391	3	Blade, Mulch 16.25 (.94 Hole)
29	103-3330	1	Spring-Extension	73	103-6386	3	Blade, Low Lift 16.25 (.94 Hole)
30	3296-39	19	Nut-Nyloc 3/8-16	73	103-6381	3	Blade, Solid 16.25 (.94 Hole)
31	103-3506	1	Seal-Single Lip	73	103-6396	3	Blade, Extreme 16.25 (.94 Hole)
32	32120-10	2	Ring-Retaining	74	1-513547	2	Spacer
33	302-40	1	Zerk-90° 1/4-28	75	1-513810	4	Bushing-Flanged
34	3234-11	1	Screw-HH Flg 3/8-16 X 1	76	106-7159	2	O-Ring
35	3256-24	3	Washer-3/8 Sae	77	103-5677	1	Spacer
36	1-413099	1	Pulley-Idler	78	103-3505	1	Seal-Double Lip
37	103-8585	1	Kit, Idler Arm (103-7356-03) W/Brgs ●	79	103-2916	1	Guard-Top
38	103-3504	2	Bearing-Spherical	80	109-0977	1	Pulley,Idler 5"
39	1-613098	1	Pulley-Idler	81	116-0962	1	Spring, Torsion
40	1-413113	2	Bushing-Idler	82	1-373034	2	Washer
41	3296-29	6	Nut-Nyloc 5/16-18	83	103-4051	1	Kit,Anti-Scalp Roller
42	32128-20	3	Nut-Whizlock 5/16-18				
43	109-8854	1	Pin-Chute				
44	1-603001	2	Rod, Deck Support				
45	1-806332	2	Rollpin 1/4 X 1 1/2				
46	322-2	3	Screw-HH 5/16-18 X 5/8				

● Assembly also includes Washer and Screw

■ Requires installation of mulch kit for proper mulching. See your Exmark dealer for details.

▲ Apply Mobil HTS grease (P/N 103-5217 1.5 oz packet) (or a food-grade anti-seize). See operator s manual for locations.

Engine Deck Assembly

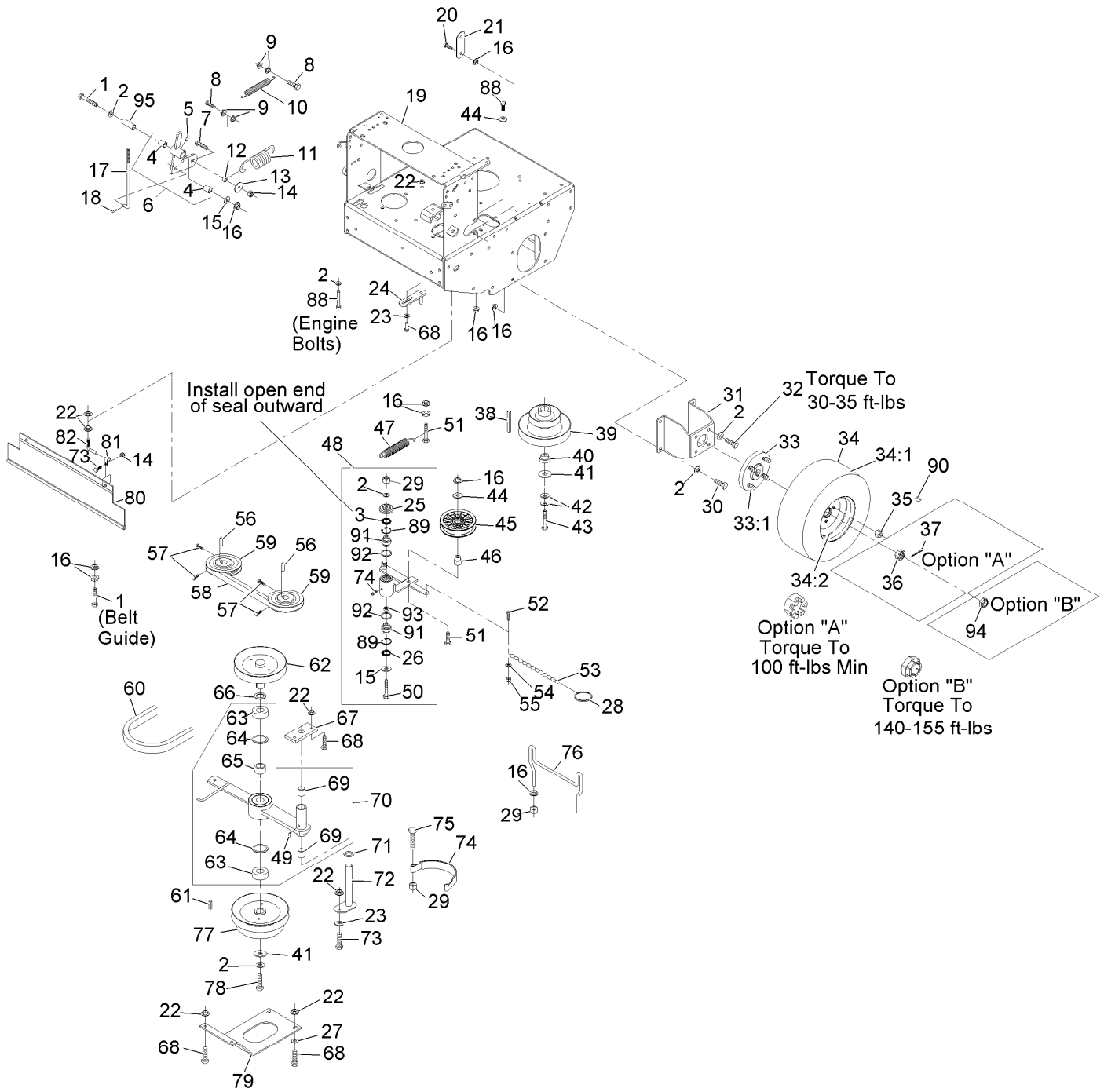

Engine Deck Assembly (continued)

<i>Ref.</i>	<i>Part Number</i>	<i>Qty.</i>	<i>Description</i>	<i>Ref.</i>	<i>Part Number</i>	<i>Qty.</i>	<i>Description</i>
1	323-11	2	Screw-HH 3/8-16 X 2 1/4	44	3256-24	2	Washer-3/8 Sae
2	98-5975	23	Washer-Spring Disc 3/8	45	109-4077	1	Pulley-Idler, Flat
3	103-3506	1	Seal-Single Lip	46	1-603496	1	Bushing-Idler
4	1-513034	2	Sleeve-Bearing	47	103-8599	1	Spring, Extension
5	302-19	1	Zerk-1/4-28 Str	48	109-1296	1	Kit, Idler Arm (109-1208-03) W/Brgs
6	1-414143	1	Asm, Bellcrank (1-412285-03) W/Brgs	49	1481	2	Zerk-45° 1/4-28
7	322-6	1	Screw-HH 5/16-18 X 1 1/4	50	98-5961	1	Screw-HH 3/8-16 X 4 Gr8
8	321-6	2	Screw-HH 1/4-20 X 1	51	323-9	2	Screw-HH 3/8-16 X 1 3/4
9	32128-33	4	Nut-Whizlock 1/4-20	52	1-809069	1	Screw-HSH #10-24 X 7/8
10	1-523498	1	Spring, Motion Control	53	1-323365	1	Chain-Link, Twist
11	103-7398	1	Spring, Belt Tension	54	3256-14	1	Washer-#10 Std
12	1-543007	1	Spacer	55	3296-2	1	Nut-Nyloc #10-24
13	1-213069	1	Washer	56	1-807272	2	Key-5Mm X 5Mm X 25Mm
14	3296-29	3	Nut-Nyloc 5/16-18	57	1-803050	4	Setscrew-5/16-18 X 3/4 ■
15	3256-4	2	Washer-3/8 Std	58	109-1057	1	Belt, Pump Drive
16	3290-357	19	Nut-Whizlock 3/8-16	59	1-413010	2	Sheave ASM ●
17	1-413282	1	Linkage	60	103-6317	1	Belt, Blade Clutch
18	1-806003	1	Hairpin-Cotter	61	1-807259	1	Key-Machine 1/4 X 1/4 X 1
19	109-1297	1	Asm, Deck (116-1682-01) W/Decals	62	103-6308	1	Sheave W/Shaft ●
20	323-4	2	Screw-HH 3/8-16 X 3/4	63	1-413111	2	Bearing, Clutch ●
21	1-633068	1	Arm-Lift, Deck	64	32120-8	2	Ring-Retaining
22	32128-20	11	Nut-Whizlock 5/16-18	65	1-413012	1	Spacer, Bearing
23	1-303334	2	Washer-Spring Disc 5/16	66	1-523157	1	Washer
24	1-322110	1	Guide-Belt	67	1-413049-01	1	Plate, Clutch Pivot
25	103-2916	1	Guard-Top	68	322-5	7	Screw-HH 5/16-18 X 1
26	103-3505	1	Seal-Double Lip	69	1-413207	2	Pivot, Bearing
27	3256-3	2	Washer-5/16 Std	70	1-414418	1	Asm, Clutch Arm (1-412417-03) W/Bearings
28	1-323366	1	Ring-Split	71	1-413235	1	Washer, Spacer
29	3296-39	5	Nut-Nyloc 3/8-16	72	1-412138-03	1	Wld, Pivot Pin
30	323-6	8	Screw-HH 3/8-16 X 1	73	322-3	3	Screw-HH 5/16-18 X 3/4
31	1-412082-01	2	Mount, Wheel Motor (48& 52)	74	1-413062	1	Band, Brake
32	323-6	8	Screw-HH 3/8-16 X 1	75	323-8	2	Screw-HH 3/8-16 X 1 1/2
33	1-602997	2	Hub ASM W/Studs	76	103-6310	1	Wld, Belt Guide
33:1	1-633926	8	Stud-Wheel	77	1-412028	1	Sheave W/Drum ●
34	1-613263	2	Wheel And Tire ASM	78	1-800521	1	Screw-HH 3/8-24 X 1 ■
34:1	1-613264	2	Tire-Turfmaster	79	1-413009-01	1	Plate, Guard
34:2	1-603715	2	Wheel-Rim	80	103-2056	1	Shield-Drag
35	242-50	8	Nut-Lug 1/2-20	81	1-413510	2	Clip-Loom
36	32136-5	2	Nut-Slotted 3/4-16	82	1-413511	2	Hanger, Drag Shield
37	1-806800	2	Pin-Cotter 9/64 X 1 1/2	88	323-7	5	Screw-HH 3/8-16 X 1 1/4
38	1-807264	1	Key-Machine 1/4 X 1/4 X 2 5/8	89	32120-10	2	Ring-Retaining
39	103-6309	1	Asm, Drive Sheave ●	90	1-807019	2	Key-Woodruff 1 X 1/4
40	1-603609	1	Bushing	91	103-3504	2	Bearing-Spherical
41	1-373034	2	Washer	92	106-7159	2	O-Ring
42	1-603610	2	Washer-Spring Disc 7/16	93	103-5677	1	Spacer
43	3212-10	1	Screw-HH 7/16-20 X 2 1/2 ■	94	116-2839	2	Nut-Lock
				95	1-603044	1	Bushing

● Apply anti-seize compound in bore.

■ Use Pro-Lock, Nut Type (P/N 1-840022, .5ml tube) on threads.

Engine Deck Assembly (cont.)

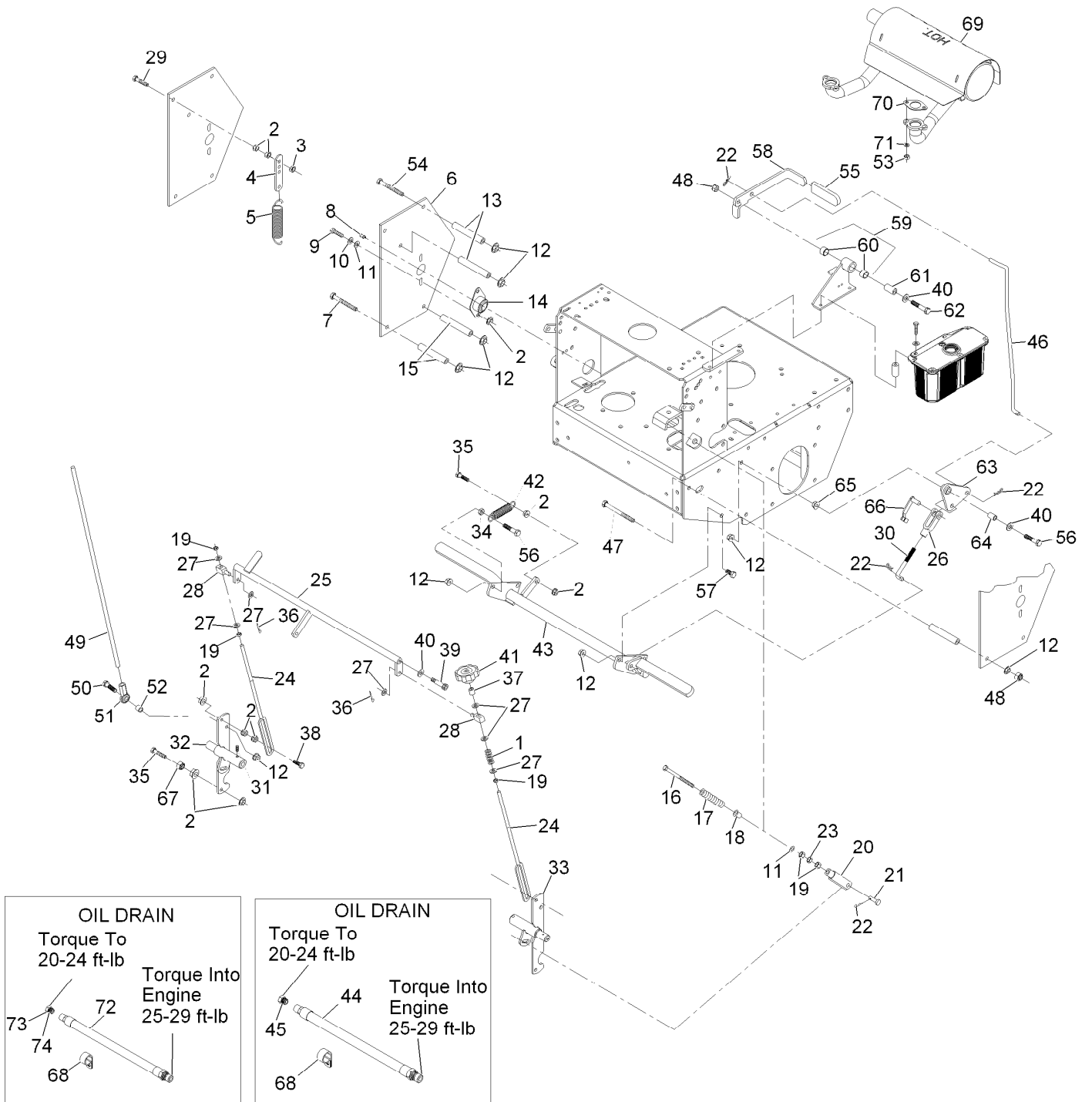

Engine Deck Assembly (cont.) (continued)

<i>Ref.</i>	<i>Part Number</i>	<i>Qty.</i>	<i>Description</i>	<i>Ref.</i>	<i>Part Number</i>	<i>Qty.</i>	<i>Description</i>
1	1-323245	1	Spring-Compression	39	1-809056	2	Screw-Sh 5/16-18 X 1 3/8 ■
2	32128-20	20	Nut-Whizlock 5/16-18	40	3256-24	4	Washer-3/8 Sae
3	3296-29	2	Nut-Nyloc 5/16-18	41	103-3060	1	Knob-Tracking
4	1-613089	2	Tab-Spring, Extension	42	1-323161	1	Spring
5	1-603693	2	Spring	43	103-2085-03	1	Brake ASM
6	110-4897-01	2	Shield-Control	44	109-0877	1	Asm, Oil Drain W/Plug ●
7	323-16	6	Screw-HH 3/8-16 X 4	45	109-1012	1	Plug
8	302-19	2	Zerk-1/4-28 Str	46	1-413492	1	Linkage, Upper Brake
9	322-3	4	Screw-HH 5/16-18 X 3/4	47	323-23	1	Screw-HH 3/8-16 X 4-1/2
10	1-805005	4	Washer-Lock 5/16 Heavy	48	3296-39	2	Nut-Nyloc 3/8-16
11	3256-2	6	Washer-1/4 Std	49	103-1148	2	Rod, Drive Lever
12	3290-357	15	Nut-Whizlock 3/8-16	50	323-8	2	Screw-HH 3/8-16 X 1 1/2
13	1-323195-01	4	Spacer-Shield	51	103-1167	2	Joint-Ball End, .38X.38Fe LH
14	1-633102	2	Bearing-Flanged				
15	1-323197-01	4	Spacer-Shield	52	103-1166	2	Spacer-Tube, Pump Link
16	1-603737	2	Bolt-Neutral Return	53	114-3549	4	Nut-M8
17	103-0265	2	Spring, Neutral Return	54	323-16	1	Screw-HH 3/8-16 X 4
18	1-603735	2	Bushing-Flanged	55	1-303020	1	Grip-Lever
19	3219-2	7	Nut-Hex 5/16-24	56	323-9	2	Screw-HH 3/8-16 X 1 3/4
20	1-303105	2	Yoke-Adjustable	57	323-4	3	Screw-HH 3/8-16 X 3/4
21	1-808280	2	Pin-Clevis 5/16 X 1 49/64	58	103-3495	1	Lever, Brake (1-412501-03) W/Decal & Grip
22	1-806003	5	Hairpin-Cotter	59	1-414504	1	Bracket ASM
23	3220-2	2	Nut-Jam 5/16-24	60	1-413347	2	Sleeve-Bushing
24	1-413350	2	Link-Control, Speed	61	1-413344	1	Bushing-Pivot
25	1-412203-01	1	Crank-Control, Speed	62	323-10	1	Screw-HH 3/8-16 X 2
26	1-633131	1	Yoke-Linkage, Brake	63	1-414508	1	Bellcrank ASM
27	3256-23	7	Washer-5/16 Sae	64	1-303548	1	Bushing-Plastic
28	1-603676	2	Swivel-Adjustable, Short	65	32128-21	1	Nut-3/8-16 Flanged Side Lock
29	1-800016	2	Bolt-HH 5/16-18 X 1 1/4 Tap				
30	1-413489	1	Linkage-Lower	66	103-2399	1	Pin-Clevis Spring 3/8
31	1-803022	2	Setscrew-5/16-18 X 5/8 ■	67	3218-2	2	Nut-Jam 5/16-18
32	103-1190-01	1	Shaft-Control, LH	68	1-643312	1	Clip-Loom
33	103-4796-01	1	Shaft-Control, RH	69	116-4397	1	Muffler
34	3218-3	1	Nut-Jam 3/8-16	70	1-653313	2	Gasket-Exhaust
35	116-3515	3	Screw,HH Special 5/16-18 X 1.25	71	114-3550	4	Washer-Lock, Spring
36	3272-5	2	Pin-Cotter 3/32 X 1/2	72	116-5052	1	Asm-Oil Drain Hose W/Plug ●
37	1-603903	1	Spacer	73	353-508	1	Plug-W/O-Ring
38	1-403180	2	Screw-HH 5/16-18 X 1 1/4 Sp	74	237-42	1	O-Ring

● Use a Teflon Pipe Sealant or equivalent on threads.
 ■ Use Pro-Lock, Nut Type (P/N 1-840022, .5ml tube) on threads.

ECS Upper Handles and Controls Assembly

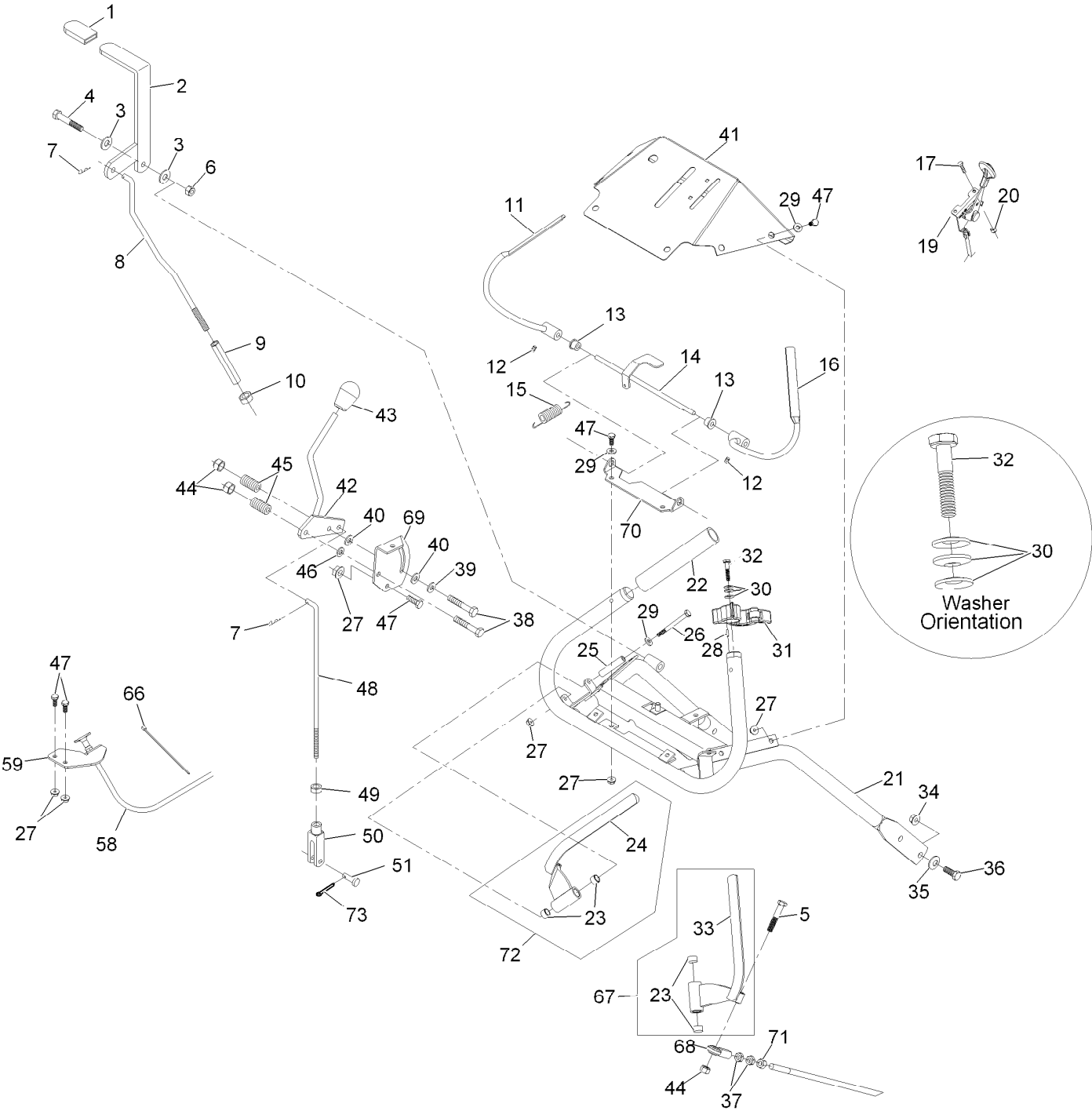

ECS Upper Handles and Controls Assembly (continued)

<i>Ref.</i>	<i>Part Number</i>	<i>Qty.</i>	<i>Description</i>	<i>Ref.</i>	<i>Part Number</i>	<i>Qty.</i>	<i>Description</i>
1	1-303020	1	Grip-Lever	32	103-0235	2	Screw-HH 1/4-20 X 1 1/8 W/Nylon ●
2	1-414234	1	Asm, Lever (1-412295-03) W/Grip	33	116-4082-03	1	Lever, Drive RH
3	3256-4	2	Washer-3/8 Std	34	3290-357	4	Nut-Whizlock 3/8-16
4	323-11	1	Screw-HH 3/8-16 X 2 1/4	35	98-5975	4	Washer-Spring Disc 3/8
5	322-9	2	Screw-HH 5/16-18 X 1 3/4	36	323-6	4	Screw-HH 3/8-16 X 1
6	3296-39	1	Nut-Nyloc 3/8-16	37	3220-3	4	Nut-Jam 3/8-24
7	1-806003	2	Hairpin-Cotter	38	322-10	4	Screw-HH 5/16-18 X 2
8	103-1149	1	Link, Blade Engagement	39	1-603716	1	Washer-Friction Disc
9	1-413279	1	Turnbuckle	40	1-323244	2	Washer-Friction
10	3217-7	1	Nut-Hex 3/8-16	41	109-4651	1	Asm, Console (109-4649-03)W/ Decals
11	116-4079	1	Wld, Lever, Opc (LH) ■	42	116-4083	1	Wld, Speed Shift
12	1-803322	2	Setscrew-5/16-24 X 5/16 ●	43	103-0423	1	Knob-Nyloc 3/8-16
13	1-303365	2	Bushing-Nylon	44	3296-29	4	Nut-Nyloc 5/16-18
14	103-0769-03	1	Wld, Opc Axle Lever	45	1-323245	2	Spring-Compression
15	1-303363	1	Spring-Extension	46	3256-23	1	Washer-5/16 Sae
16	116-4080	1	Wld, Opc Lever (RH) ■	47	321-3	12	Screw-HH 1/4-20 X 5/8
17	1-807513	2	Bolt-Carriage #10-24 X 1/2	48	1-413225	1	Rod, Speed Control
19	116-2426	1	Cable, Throttle	49	3220-2	1	Nut-Jam 5/16-24
20	3296-2	2	Nut-Nyloc #10-24	50	1-303105	1	Yoke-Adjustable
21	103-0770-03	1	Wld, Handle	51	1-808280	1	Pin-Clevis 5/16 X 1 49/64
22	103-0815	2	Grip-Bar, Handle	58	103-1796	1	Cable-Choke
23	1-413152	4	Bushing-Sleeve	59	103-1797-01	1	Bracket-Cable, Choke
24	116-4081-03	1	Lever, Drive LH	66	1-303287	1	Tie-Cable 5 1/2 (Small)
25	103-0027	2	Bushing-Lever, Drive	67	103-2513	1	Asm, Drive Lever RH
26	321-14	2	Screw-HH 1/4-20 X 2 3/4	68	103-2463	2	Balljoint
27	32128-33	14	Nut-Whizlock 1/4-20	69	103-0503	1	Bracket, Shifter Slide
28	103-0464	2	Pin-Spring 1/8 X 1/2	70	103-0489-03	1	Bracket, Opc Axle
29	3256-22	10	Washer-1/4 Sae	71	3219-3	2	Nut-Hex 3/8-24
30	1-303435	6	Washer-Spring Disc 1/4	72	103-2514	1	Asm, Drive Lever LH
31	103-1371	1	Thumb Latch Asm RH(Shown)	73	3272-5	1	Pin-Cotter 3/32 X 1/2
31	103-1372	1	Thumb Latch Asm LH(Not Shown)				

● Use Pro-Lock, Nut Type (P/N 1-840022, .5ml tube) on threads.

■ Use Pro-Lock retaining type, Part no. 1-840023 (.5cc tube) on inside of bore of OPC hub.

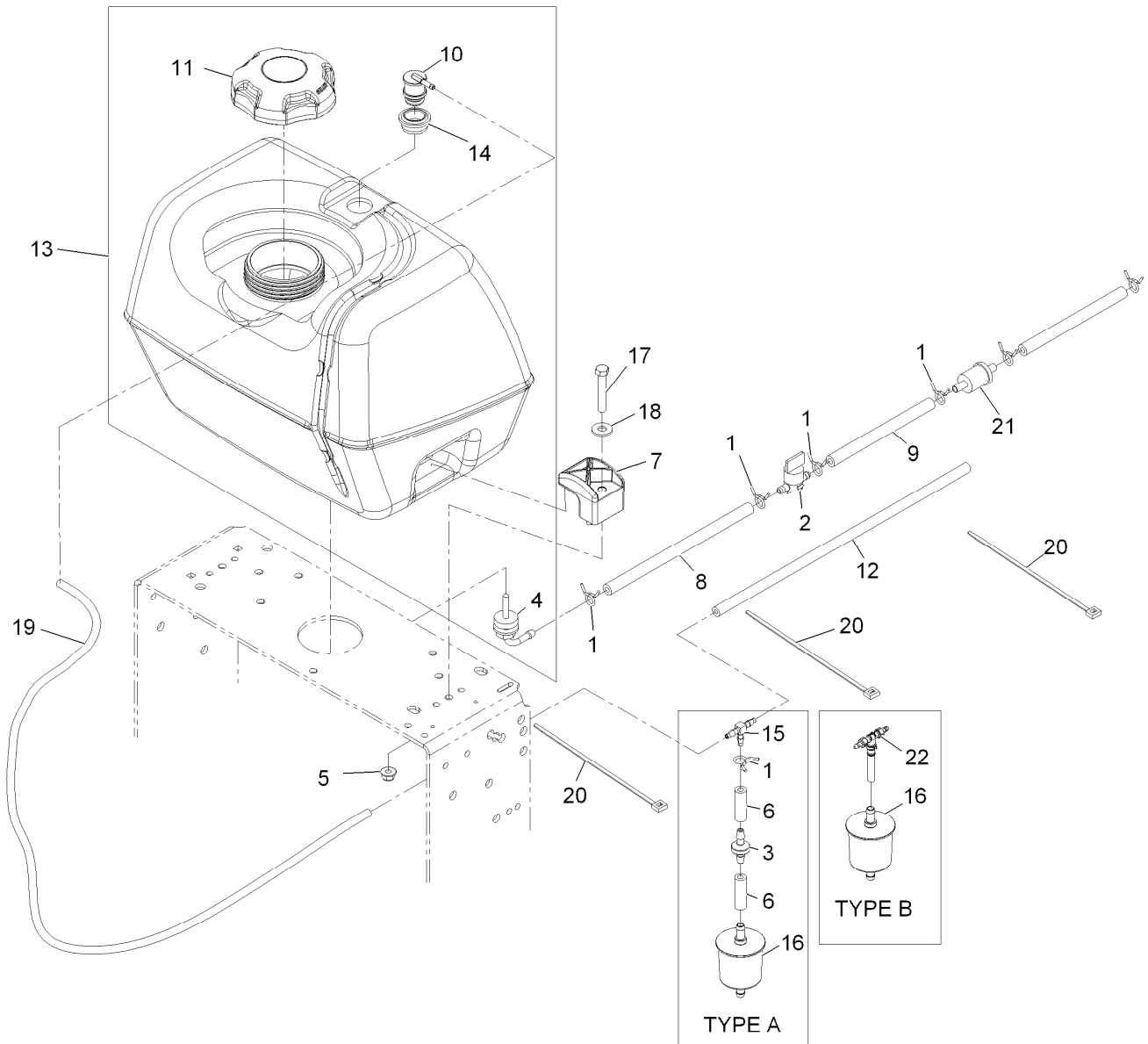

Fuel Tank Assembly

Ref.	Part Number	Qty.	Description
1	2412-98	5	Clamp-Hose
1	2412-98	4	Clamp-Hose
2	1-603770	1	Valve-Fuel
3	99-5000	1	Valve-Check, Fuel
4	103-2605	1	Fitting-Fuel Bulkhead W/Strainer ▲
5	104-8300	2	Nut-Nyloc 5/16-18 Flg
6	106-9492	2	Hose-Fuel
7	107-4543	2	Clamp
8	109-0650	1	Hose-Fuel
9	99-9415	1	Hose-Fuel
10	114-0285	1	Valve-Rollover
11	120-5461	1	Cap-Fuel, Ratcheting

Ref.	Part Number	Qty.	Description
12	115-7872	1	Hose-Fuel
13	116-3656	1	Asm-Fuel Tank
14	114-0284	1	Grommet
15	120-2234	1	Fitting-Tee
16	120-2235	1	Filter-Air
17	322-10	2	Screw-HH 5/16-18 X 2
18	3256-3	2	Washer-5/16 Std
19	116-4346	1	Hose-Emissions
20	1-303335	3	Tie-Cable 7 15/16 (Large)
21		1	Pn 41019-1055 Filter W/6In Fuel Line ■●
22	116-5464	1	Asm-Tee And Check

● Not serviced separately

▲ Use Pro-Lock, Nut Type (P/N 1-840022, .5ml tube) on threads.

■ Obtain parts from www.kawpowerepc.com

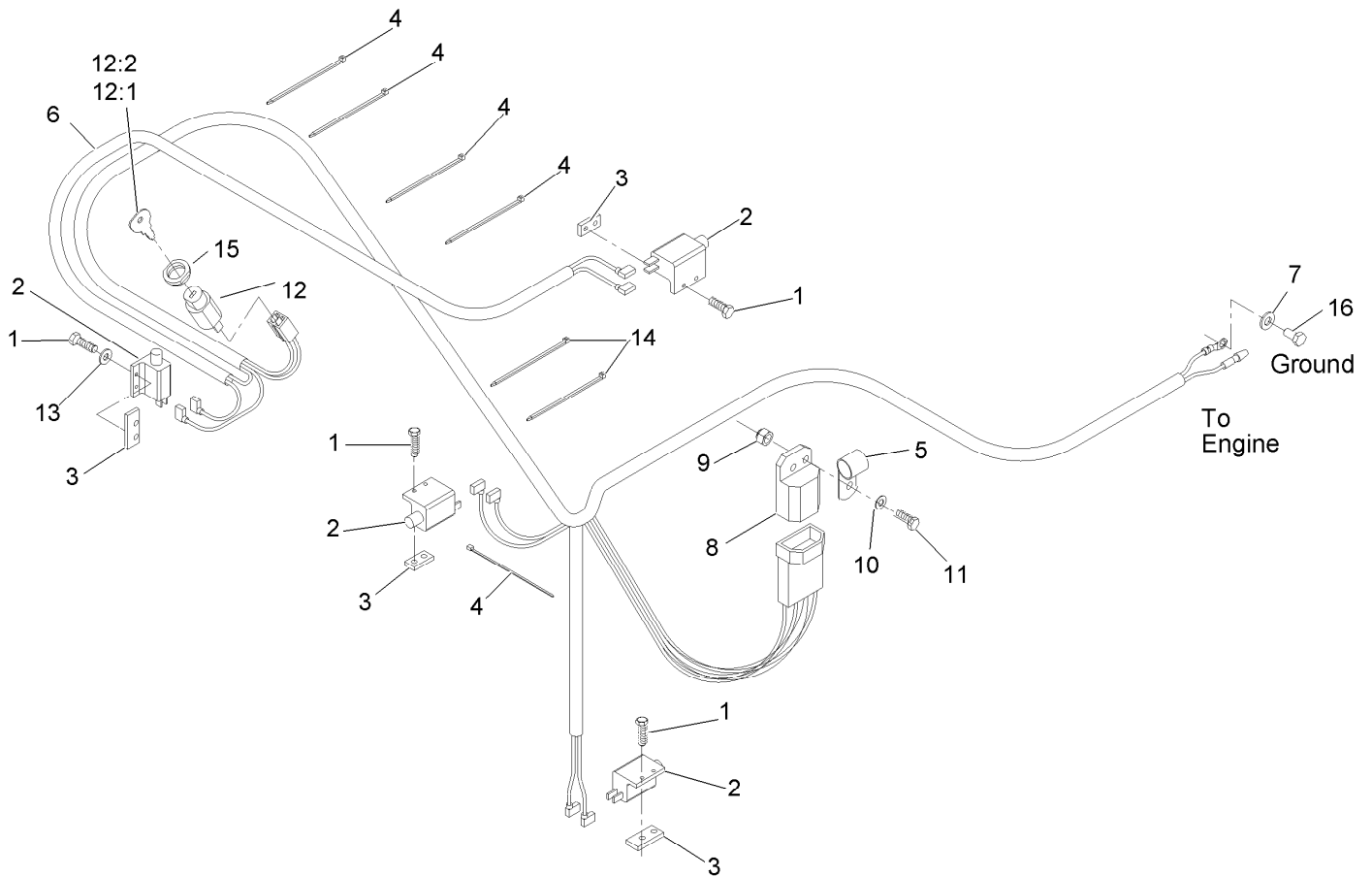

Electrical Assembly

Ref.	Part Number	Qty.	Description	Ref.	Part Number	Qty.	Description
1	3290-500	8	Screw-PPH #10-24 X 5/8	10	3256-22	1	Washer-1/4 Sae
2	1-513051	4	Switch-N.O.	11	321-4	1	Screw-HH 1/4-20 X 3/4
3	1-633181	4	Plate-Tapped	12	1-403121	1	Switch-Key
4	1-303287	5	Tie-Cable 5 1/2 (Small)	12:1	1-603511	1	Key-Ignition
5	1-323229	1	Clip-Loom 3/8	12:2	103-2106	1	Key-Exmark Logo
6	116-2610	1	Harness, Wiring	13	3256-14	1	Washer-#10 Std
7	33094-00	1	Washer	14	1-303335	2	Tie-Cable 7 15/16 (Large)
8	1-323430	1	Module-Interlock	15	103-0498	1	Nut-Ignition
9	3296-42	1	Nut-Nyloc 1/4-20	16	33114-016	1	Screw-HH M8-1.25 X 16Mm

Hydraulic Assembly

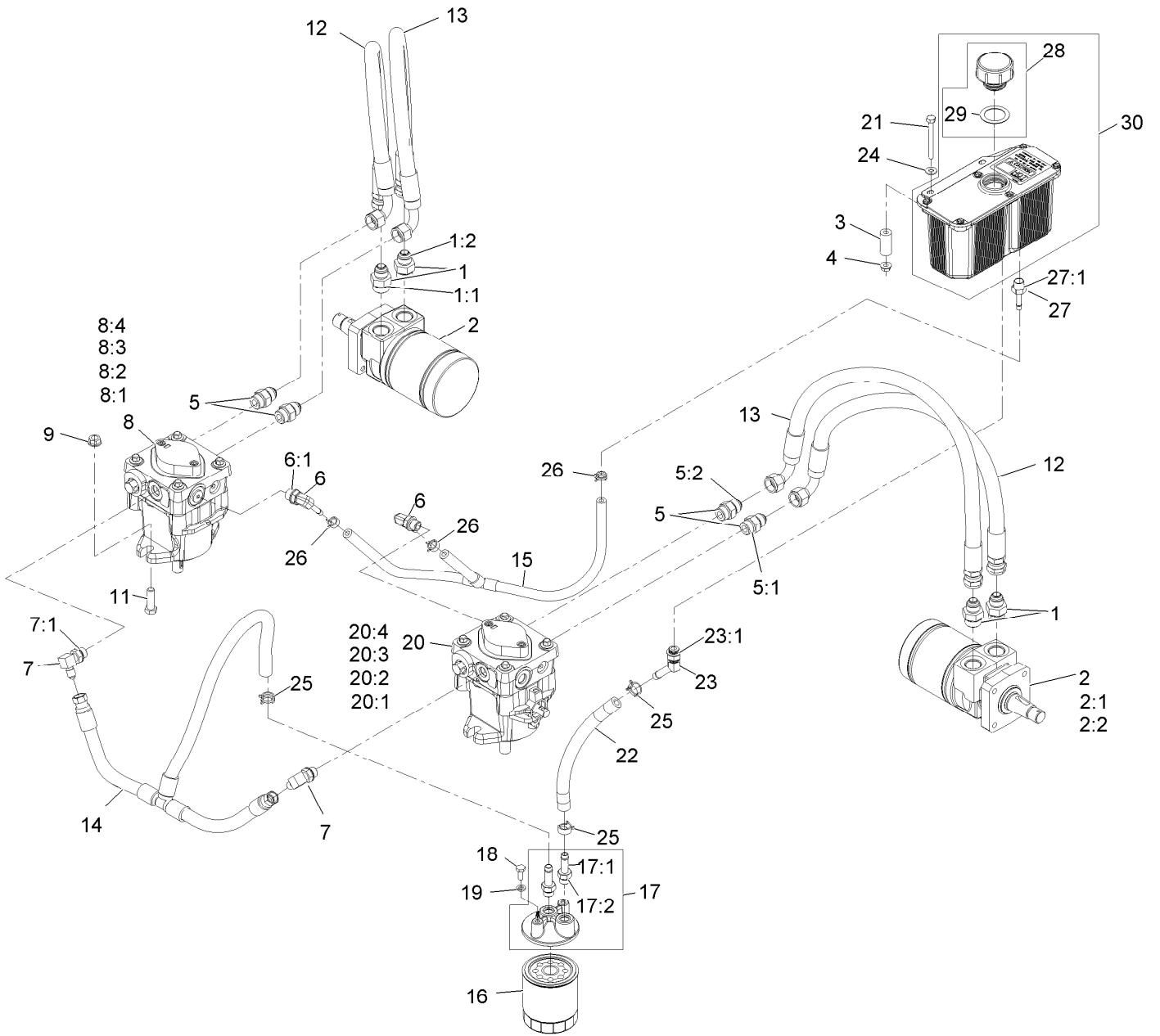

Hydraulic Assembly (continued)

<i>Ref.</i>	<i>Part Number</i>	<i>Qty.</i>	<i>Description</i>	<i>Ref.</i>	<i>Part Number</i>	<i>Qty.</i>	<i>Description</i>
1	1-603991	4	Adapter-Straight	16	109-4180	1	Filter,25 Micron
1:1	1-603919	1	O-Ring-Sae #10				Bi-Directional
1:2	1-603992	1	O-Ring-37 Flare #8	16	1-523541	1	Element, Oil Filter(Winter) ●
2	1-603718	2	HYD Motor ASM	17	103-2889	1	Filter Head ASM
2:1	1-000138	1	Bearing And Seal Kit	17:1	103-1912	2	Adapter-Straight
2:2	1-000119	1	Seal Kit	17:2	1-603921	1	O-Ring-Sae #6
3	103-2191	2	Spacer	18	321-3	2	Screw-HH 1/4-20 X 5/8
4	32128-33	2	Nut-Whizlock 1/4-20	19	1-805004	2	Washer-Lock 1/4 Heavy
5	1-603990	4	Adapter-Straight	20	116-0943	1	RH HYD Pump ASM
5:1	1-603920	1	O-Ring-Sae #8	20:1	103-2664	1	Input Shaft Kit
5:2	1-603992	1	O-Ring-37 Flare #8	20:2	94-6922	1	Bearing-Thrust
6	103-1799	2	Elbow-90 DEG	20:3	103-2666	1	Cylinder Block Kit
6:1	1-603921	1	O-Ring-Sae #6	20:4	105-6184	1	Seal Overhaul Kit
7	103-1802	2	Fitting-HYD, 90 DEG	21	321-15	2	Screw-HH
7:1	1-603921	1	O-Ring-Sae #6	22	103-2959	1	Hose-Charge
8	116-0942	1	LH HYD Pump ASM	23	103-1807	1	Fitting-Barbed, 45 DEG
8:1	103-2664	1	Input Shaft Kit	23:1	1-603921	1	O-Ring-Sae #6
8:2	94-6922	1	Bearing-Thrust	24	3256-22	2	Washer-1/4 Sae
8:3	103-2666	1	Cylinder Block Kit	25	103-1988	3	Clamp-Hose 11/16
8:4	105-6184	1	Seal Overhaul Kit	26	103-1716	3	Clamp-Hose 17/32
9	32128-43	4	Nut-Whizlock 3/8-16	27	103-1801	1	Adapter-Straight
11	323-7	4	Screw-HH 3/8-16 X 1 1/4	27:1	1-603921	1	O-Ring-Sae #6
12	1-613034	2	Hose-Pressure, High	28	103-7615	1	Asm, Cap W/Gasket
13	1-323241	2	Hose-Pressure, High	29	103-1949	1	Gasket-Cap
14	116-2123	1	Charge Hose ASM	30	103-1947	1	HYD Reservoir ASM
15	116-0918	1	Case Drain Hose ASM				

● Use only for operation below 32°F (0°C).

Decals

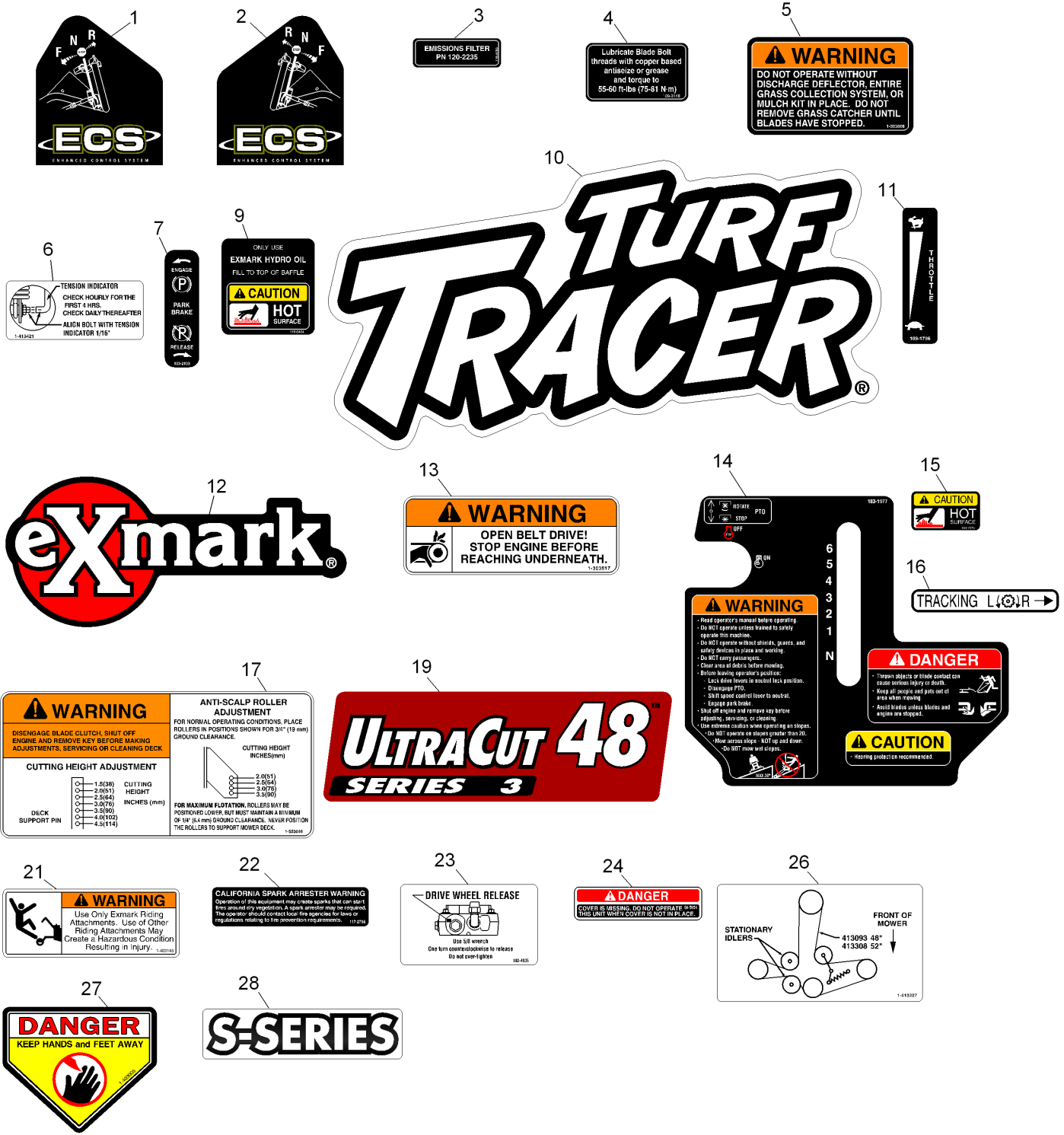

Decals (continued)

<i>Ref.</i>	<i>Part Number</i>	<i>Qty.</i>	<i>Description</i>	<i>Ref.</i>	<i>Part Number</i>	<i>Qty.</i>	<i>Description</i>
1	103-2242	1	Decal, LH Ecs Instruction	15	103-2076	2	Decal-Caution
2	103-2243	1	Decal, RH Ecs Instruction	16	1-413214	1	Decal, Tracking
3	116-4769	1	Decal-Filter, Emissions	17	1-553049	1	Decal-Anti Scalp
4	109-3148	1	Decal,Bolt Torque	19	116-4697	1	Decal-Ultracut 48 Series 3
5	1-303508	1	Decal-Warning, Discharge	21	1-403143	1	Decal, Sulky Warning
6	1-413421	1	Decal, Indicator	22	117-2718	1	Decal-Arrester, Spark
7	103-2103	1	Decal-Brake, Park	23	103-4935	1	Decal, Drive Wheel Release
9	116-0404	1	Decal-Hydraulic Tank	24	98-5954	3	Decal-Cover, Missing
10	103-3013	1	Decal-Turf Tracer	26	1-413327	1	Decal, Belt Routing
11	103-1798	1	Decal, Throttle	27	1-403005	2	Decal-Danger
12	103-2882	1	Decal,Exmark Logo	28	116-3884	2	Decal-S-Series
13	1-303517	1	Decal,Belt Drive	99	103-2461	1	Decal Kit ●
14	103-1977	1	Decal, Ecs Console				

● Not illustrated

SEE EXMARK'S COMPLETE LINE OF ACCESSORIES AND OPTIONS

MID-MOUNT RIDING ACCESSORIES AND OPTIONS

CUSTOM RIDE SEAT SUSPENSION SYSTEM	OPERATOR CONTROLLED DISCHARGE
FULL SUSPENSION SEAT	ROLL OVER PROTECTION SYSTEM (ROPS)
DECK LIFT ASSIST KIT	SUN SHADE
HITCH KIT	TRASH CONTAINER
LIGHT KIT	TURF STRIPER
12V POWER PORT	ULTRA VAC COLLECTION SYSTEM
MICRO-MULCH SYSTEM	ULTRA VAC QUICK DISPOSAL SYSTEM

OUT-FRONT RIDING ACCESSORIES AND OPTIONS

CUSTOM RIDE SEAT SUSPENSION SYSTEM	SNOW BLADE
DUAL-TAIL WHEEL	SNOWBLOWER
FLOOR PAN EXTENDER	SUN SHADE
HITCH KIT	TRASH CONTAINER
LIGHT KIT	ULTRA VAC COLLECTION SYSTEM
MICRO-MULCH SYSTEM	ULTRA VAC QUICK DISPOSAL SYSTEM
ROLL OVER PROTECTION SYSTEM (ROPS)	WEATHER CAB

WALK-BEHIND ACCESSORIES AND OPTIONS

GRASS CATCHER	TURF STRIPER
MICRO-MULCH SYSTEM	STANDON

Place Model No. and Serial No.
Label Here (Included in the Literature
Pack) or Fill in Below

Model No. _____

Serial No. _____

Date Purchased _____

Engine Model No. and Spec. No. _____

Engine Serial No. (E/No) _____

© 2011 Exmark Mfg. Co., Inc.
Industrial Park Box 808
Beatrice, NE 68310
All Rights Reserved

Part No. 4500-772 Rev. B
(402) 223-6300
Fax (402) 223-5489
Printed in the USA.

