

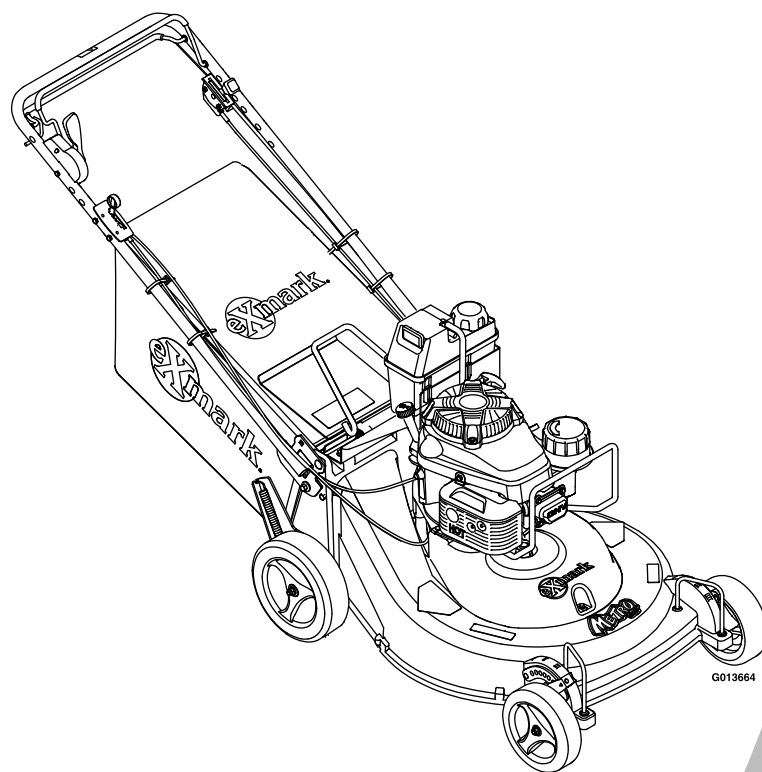

METRO[®] 26

Model No. MSKABBC26—Serial No. 31200000 and Up

Picture below may not reflect actual product.



Parts Manual

Ordering Replacement Parts

To order replacement parts, please supply the part number, the quantity, and the description of each part desired.

Understanding Reference Numbers

Each identified part in an illustration has a reference number. The reference number for a part also appears in the parts list, along with other information about the part.

This catalog uses two special reference number formats, one to indicate parts in a service assembly and another to indicate the quantity of a given part in an illustration.

Service Assembly Reference Numbers

Parts in service assemblies have reference numbers in the form a:b. The a represents the reference number of the entire service assembly and the b represents a sequential number unique to each part within the service assembly.

For example, a wheel assembly might be identified by reference number 6, the tire by 6:1, the valve by 6:2, and the wheel by 6:3. When you order the assembly identified by reference number 6, you receive all parts identified by reference numbers 6:1, 6:2, and 6:3. However, you may also order any part individually. Reference numbers of this type appear in illustration and in parts lists.

Reference Numbers Indicating Quantity

In an illustration, if a reference number indicates more than one part, the reference number has the form nX y. The n represents the quantity of the part, the X is the multiplication symbol, and the y represents the reference number.

For example, in an illustration, the reference number 2X 37 means that two of the parts identified by reference number 37 are indicated.

List of Abbreviations

AR: as required	HJ: hex jam	PTH: phillips truss head
ASM: assembly	HLH: hex lag head	PTO: power-take-off
BBC: blade brake control	HOC: height-of-cut	RH: right hand
BHTF: button head thread forming	HSBH: hex socket button head	ROPS: roll-over protection system
CARR: carriage	HSFH: hex socket flat head	RRB: rear roller brush
CCW: counter clockwise	HSH: hex socket head	SFH: slotted fillister head
CW: clockwise	HWH: hex washer head	SHH: slotted hex head
DEG: degrees	HWHTF: hex washer head thread forming	SHWH: slotted hex washer head
DPA: Dual Point Adjustment	HYD: hydraulic	SPH: slotted pan head
ECM: electronic control module	LH: left hand	SQH: square head
EXT: external	LPG: Liquid Propane Gas	SRH: slotted round head
FH: flat head	NI: nylon insert	STD: standard
GA: gauge	NPTF: national pipe thread fine	TAP: self tapping
HD: heavy-duty	PFH: phillips flat head	TTH: torx truss head
HF: hex flange	PPH: phillips pan head	
HH: hex head	PPHTF: phillips pan head thread forming	
HHF: hex head flange	PRH: phillips round head	
HHFTF: hex head flange thread forming		

Touch Up Paint

Exmark black touch up spray paint – gloss black.

Exmark red touch up paint (spray paint – P/N 1-850337 - .6 oz liquid bottle – P/N 103-9140).



If your Exmark dealer does not have the Exmark part in stock, Exmark will get the parts to the dealer the next business day or the part will be FREE Guaranteed!! (Some restrictions apply. See your participating Exmark Dealer for details.)

Contents

- Deck and Wheel Assembly 4
- Deck Assembly 5
- Blade and Spindle Assembly 6
- Gear Case Assembly 8
- Rear Wheel Assembly 10
- Engine Assembly 11
- Handle Assembly 12
- Discharge Door and Bag Assembly 13
- Decals 14

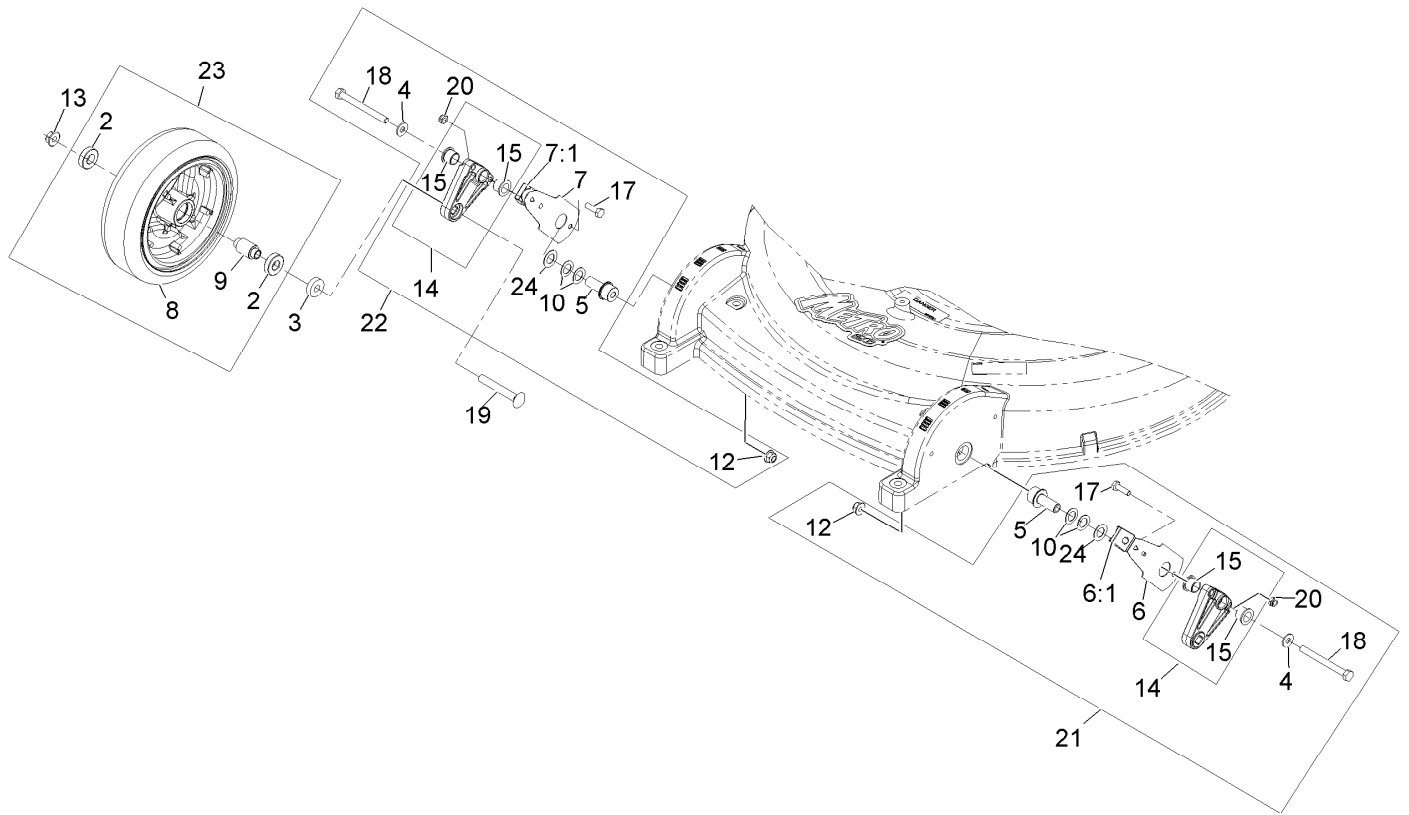

Deck and Wheel Assembly

Ref.	Part Number	Qty.	Description
2	52-2450	4	Bearing-Ball
3	62-6660	2	Spacer
4	98-3499	2	Washer
5	109-6041	2	Bushing-Pivot, Wheel
6	103-6245	1	Asm, Front Spring Arm LH
6:1	25-7740	1	Knob-Arm
7	103-6246	1	Asm, Front Spring Arm RH
7:1	25-7740	1	Knob-Arm
8	103-9976	2	Asm, Wheel And Tire
9	103-7649	2	Spacer-Wheel, Front
10	116-4280	4	Washer-Conical
12	104-8300	2	Nut-Nyloc 5/16-18 Flg

Ref.	Part Number	Qty.	Description
13	104-8301	2	Nut-Nyloc 3/8-16 Flg
14	116-4305	2	ASM-Front Wheel Arm
15	116-4279	4	Bearing-Flange
17	321-5	2	Screw-HH 1/4-20 X 7/8
18	322-20	2	Screw-HH 5/16-18 X 3 1/4
19	3231-9	2	Bolt-Carriage 3/8-16 X 2 3/4
20	3296-56	2	Nut-Nyloc 1/4-20 Thin
21	116-4306	1	Asm, LH Pivot
22	116-4307	1	Asm, RH Pivot
23	112-8706	2	8 Inch Wheel ASM
24	36-4780	2	Washer

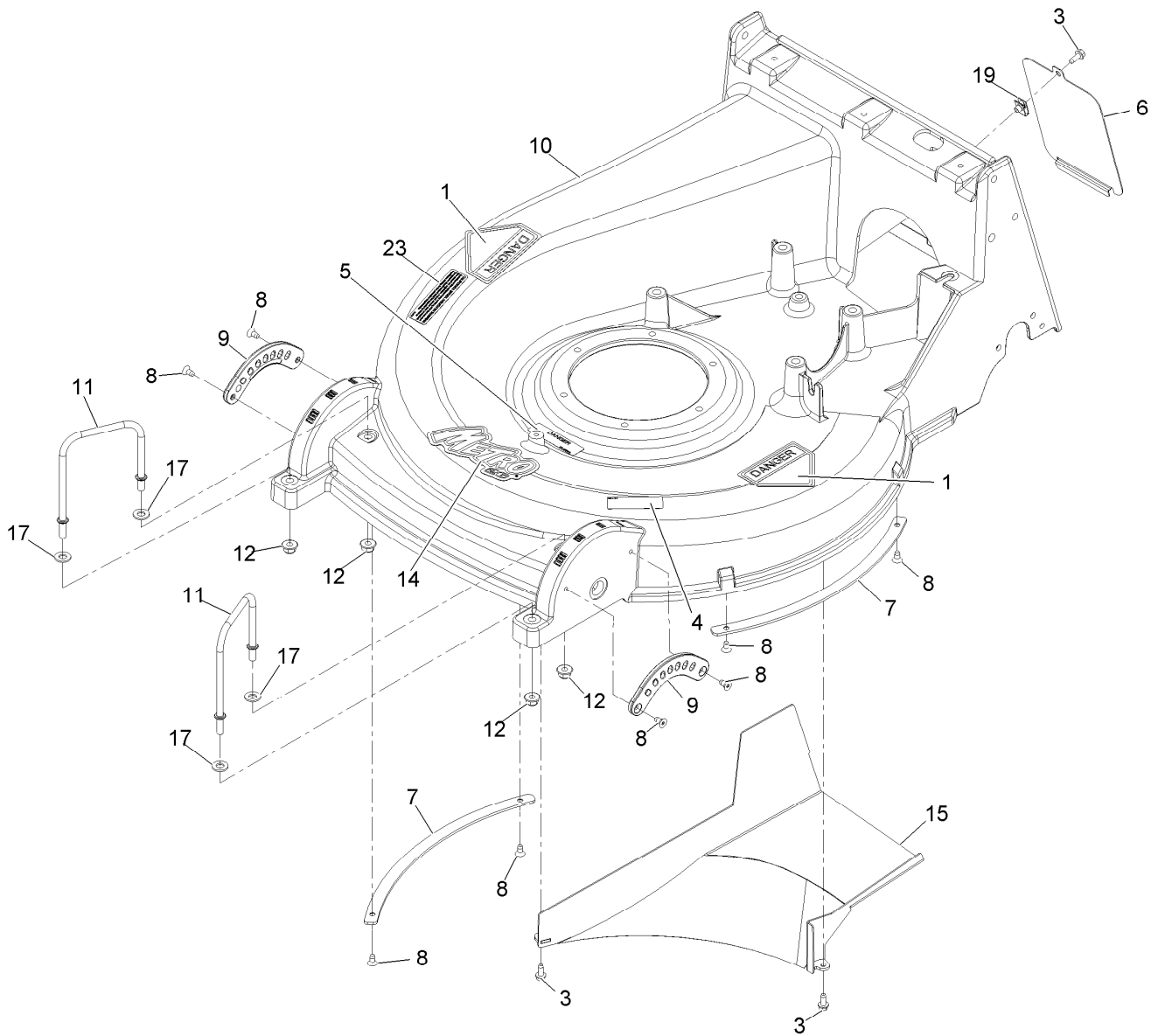

Deck Assembly

Ref.	Part Number	Qty.	Description	Ref.	Part Number	Qty.	Description
1	43-8480	2	Decal-Danger	10	109-5476	1	Asm, Deck W/Decals
3	32144-10	3	Screw-HWH 1/4-20 X .62	11	103-8875	2	Handle-Deck
4	68-7410	1	Decal-Blade	12	104-8301	4	Nut-Nyloc 3/8-16 Flg
5	98-5954	1	Decal-Cover, Missing	14	109-0046	1	Decal, Metro 26
6	116-0336	1	Cover-Access, Axle	15	116-2807-03	1	Wld, Chute Metro 26
7	116-0059-03	2	Plate-Skid, 10 Gage	17	3256-24	4	Washer-3/8 Sae
8	103-6145	8	Screw-Flat HD 1/4-20 X 1/2 Tr	19	107069	1	Nut-Retainer-Panel 1/4-20
9	103-6460	2	Quadrant-Front	23	117-2718	1	Decal-Arrester, Spark

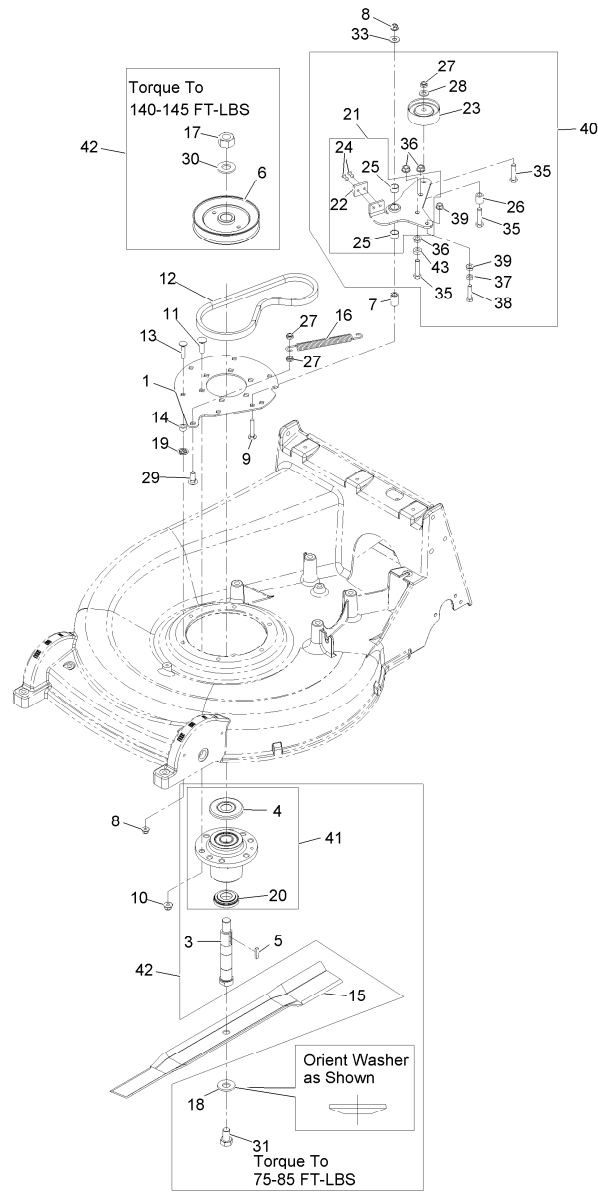

Blade and Spindle Assembly

Ref.	Part Number	Qty.	Description	Ref.	Part Number	Qty.	Description
1	116-0092-03	1	Plate-Adapter, Housing	15	103-6422	1	Blade, Mulching ■
3	109-2650	1	Shaft-Spindle ▲●	16	103-7896	1	Spring-Brake
4	103-1330	1	Guard-Bearing Top ▲	17	3217-46	1	Nut-Hex 3/4-16 Heavy
5	1-807268	1	Key-Machine 1/4 X 3/16 X 1	18	1-513208	1	Washer-Spring Disc 5/8
6	116-0821	1	Sheave-Split, Steel (W/Hub) ▲	19	78-7170	6	Nut-Push 5/16
7	103-7108	1	Bushing-Arm, Idler	20	103-2535	1	Spacer-Guard Bottom
8	104-8300	7	Nut-Nyloc 5/16-18 Flg	21	116-1408	1	Asm, Idler Arm
9	116-0629	1	Screw-Carriage 5/16-18 X 1 3/4 Short	22	116-0959	1	Pad-Brake
10	104-8301	6	Nut-Nyloc 3/8-16 Flg	23	109-3546	1	Pulley-Idler
11	3231-28	6	Bolt-Carriage 3/8-16 X 1 1/4	24	103-0138	2	Rivet 3/16 X 1/2
12	116-0823	1	Belt	25	103-6111	2	Bearing
13	3230-4	6	Bolt-Carriage 5/16-18 X 1 1/2	26	1-633080	1	Spacer
14	111044	6	Bushing	27	3296-59	3	Nut-Nyloc 3/8-16 Thin
15	109-0343	1	Blade	28	3256-24	1	Washer-3/8 Sae
				29	3231-22	1	Bolt-Carriage 3/8-16 X 1
				30	103-2802	1	Washer-Spring Disc 3/4
				31	103-1026	1	Screw-HH 5/8-11 X 1 Gr 8

● DO NOT use a copper or nickel based anti-seize.

■ Requires installation of mulch kit for proper mulching. See your Exmark dealer for details.

▲ Apply Mobil HTS grease (P/N 103-5217 1.5 oz packet) (or a food-grade anti-seize). See operator s manual for locations.

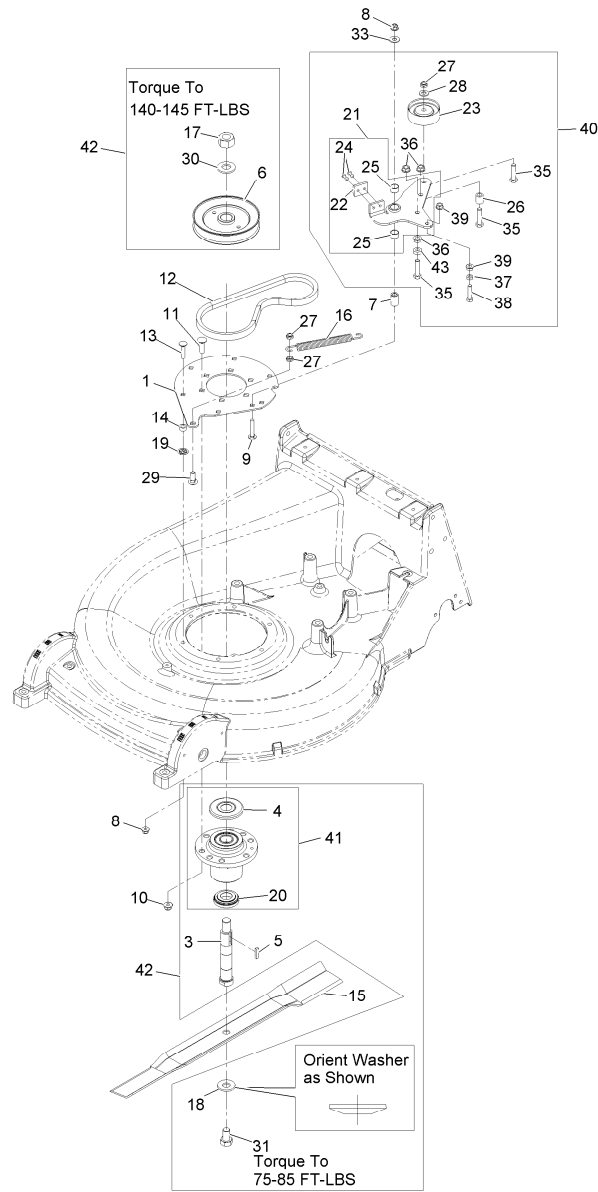

Blade and Spindle Assembly (continued)

Ref.	Part Number	Qty.	Description	Ref.	Part Number	Qty.	Description
33	3256-3	1	Washer-5/16 Std	39	32128-20	2	Nut-Whizlock 5/16-18
35	323-8	3	Screw-HH 3/8-16 X 1 1/2	40	116-0096	1	Idler Arm ASM
36	3290-357	3	Nut-Whizlock 3/8-16	41	103-8280	1	Kit, Cutter Housing
37	3218-2	1	Nut-Jam 5/16-18	42	109-3559	1	Asm, Cutter Housing Complete
38	1-403180	1	Screw-HH 5/16-18 X 1 1/4 Sp	43	3218-3	1	Nut-Jam 3/8-16

● DO NOT use a copper or nickel based anti-seize.

■ Requires installation of mulch kit for proper mulching. See your Exmark dealer for details.

▲ Apply Mobil HTS grease (P/N 103-5217 1.5 oz packet) (or a food-grade anti-seize). See operator s manual for locations.

Gear Case Assembly

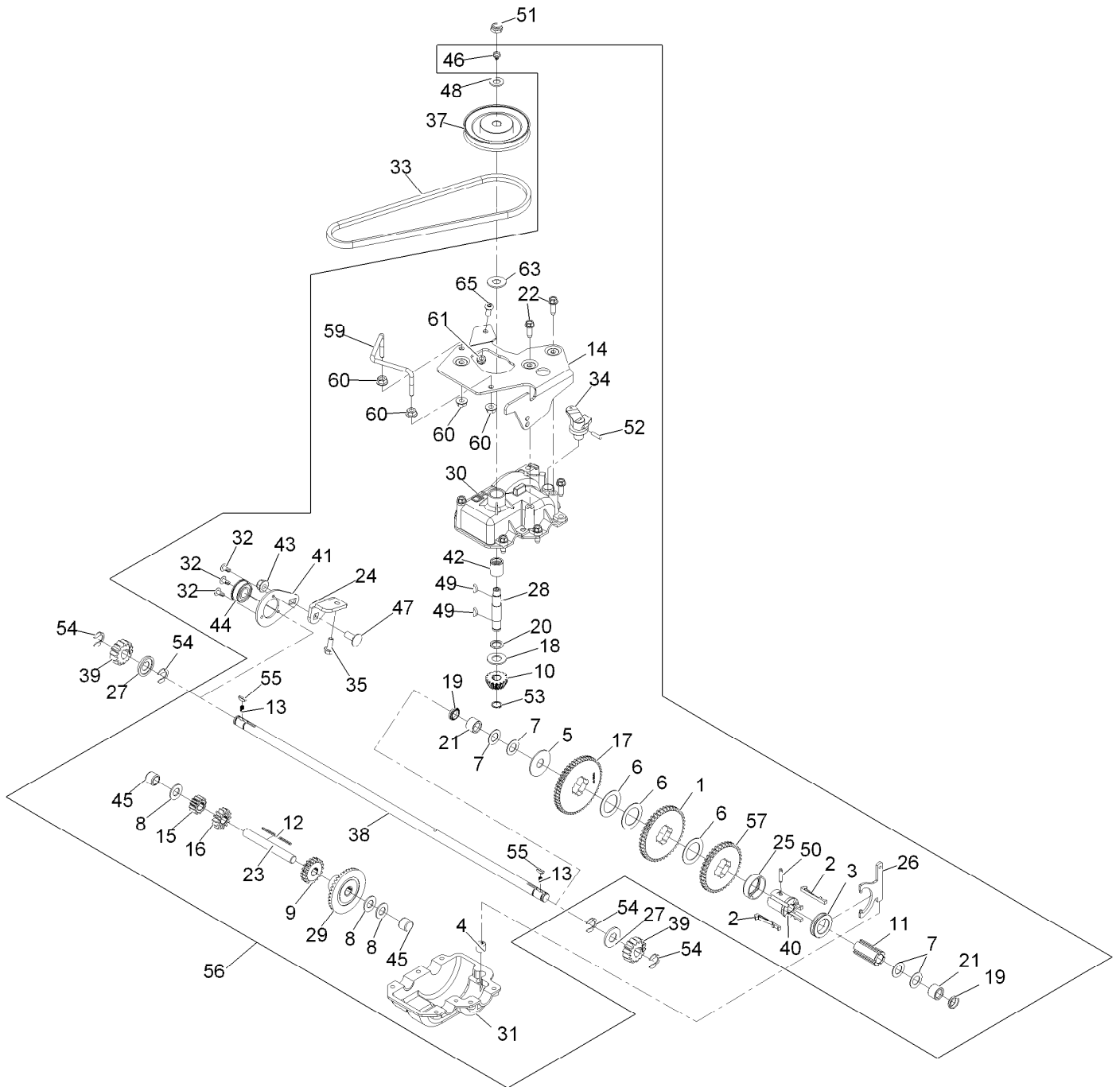

Gear Case Assembly (continued)

<i>Ref.</i>	<i>Part Number</i>	<i>Qty.</i>	<i>Description</i>	<i>Ref.</i>	<i>Part Number</i>	<i>Qty.</i>	<i>Description</i>
1	29-9271	1	Gear-42T	32	92-9665	3	Screw-Truss HD #10-12 X 1/2 Tf
2	29-9330	4	Key-Shift	33	103-6114	1	Belt-V, Traction
3	29-9340	1	Collar-Shift	34	103-6138	1	Lever-Shift
4	29-9570	1	Bushing-Yoke	35	32144-85	1	Screw-HWH 1/4-20 X .62
5	29-9690	1	Washer	37	103-6429	1	Sheave
6	36-4770	3	Washer	38	103-6435	1	Shaft-Axle
7	36-4780	4	Washer	39	103-6436	2	Gear-Pinion ●
8	36-4792	3	Washer-Thrust	40	109-2642	1	Sleeve-4 Dog
9	39-6650	1	Gear-18T	41	109-6612	1	Plate-Bearing
10	39-6660	1	Pinion-Bevel 16T	42	103-9773	1	Bearing-Roller
11	39-6720	1	Sleeve	43	104-8300	1	Nut-Nyloc 5/16-18 Flg
12	39-7842	1	Key-Machine 3/32 Sq X 2 1/8	44	116-7257	1	Bearing
13	39-9650	2	Spring	45	252-103	2	Bearing-Needle
14	116-0339-03	1	Bracket-Guide, Belt	46	302-63	1	Zerk
15	46-3540	1	Gear-12T	47	3230-23	1	Bolt-Carriage 5/16-18 X 3/4 Short Neck
16	46-3550	1	Gear-14T	48	3256-45	1	Washer-Flat
17	46-3560	1	Gear-52T	49	3257-1	2	Key-Woodruff 1/8 X 1/2
18	47-2910	1	Washer-Thrust	50	3285-19	1	Pin-Groove
19	47-6730	2	Seal-Oil	51	3296-5	1	Nut-Nyloc 3/8-24 Thin
20	47-7260	1	Seal	52	32121-99	1	Pin-Coil
21	117-3500	2	Bearing-Caged Needle Roller	53	32151-57	1	Ring-Retaining
22	49-2040	9	Screw-HWH 1/4-20 X 3/4 Tf	54	32151-68	4	E-Ring
23	53-7950	1	Shaft-Intermediate	55	612066	2	Key
24	116-0222	1	Bracket-Bearing, Plated	56	116-0785	1	Asm, Gear Case
25	55-8020	1	Retainer-Key	57	109-3130	1	Gear-38T
26	60-8870	1	Yoke-Shift	59	103-8224	1	Guide-Belt
27	62-3830	2	Washer	60	32128-33	4	Nut-Whizlock 1/4-20
28	13-5149	1	Input Shaft ASM	61	3296-56	1	Nut-Nyloc 1/4-20 Thin
29	74-1760	1	Gear-Bevel 40T	63	109-3614	1	Washer
30	109-0170	1	Gear Case-Upper	65	3274-31	1	Screw-Button Head 1/4-20 X 5/8
31	119-7863	1	Gearcase-Lower				

● Assemble both sides with P/N facing left from operator s position.

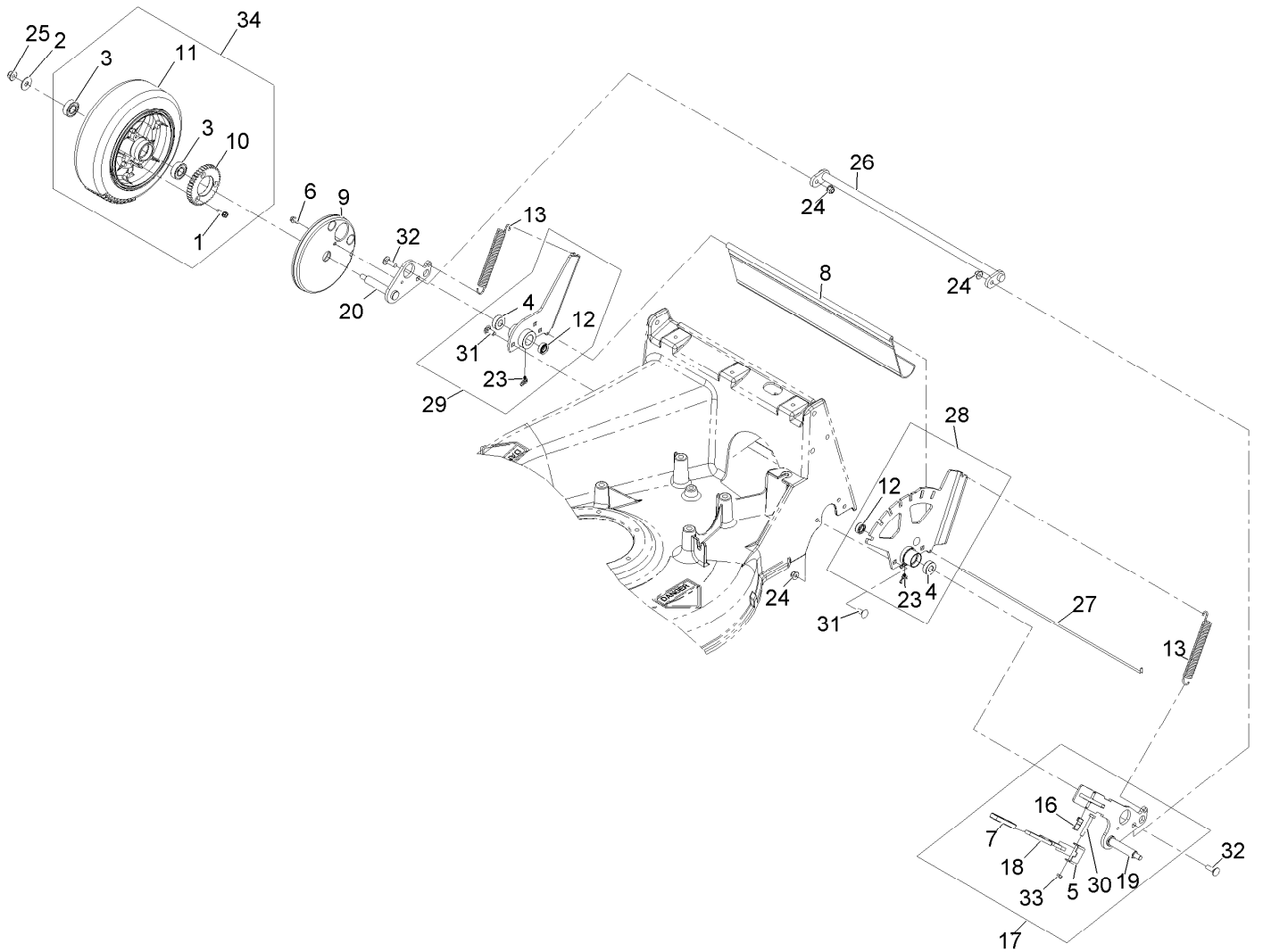

Rear Wheel Assembly

Ref.	Part Number	Qty.	Description	Ref.	Part Number	Qty.	Description
1	116-0606	6	Screw-1/4-20 X 7/8 Torx	18	103-8226	1	Lever-Lift
2	52-2860	2	Washer	19	103-8227	1	Arm-Axle, LH
3	103-6103	4	Bearing-Ball	20	103-8229	1	Arm-Axle, RH
4	103-6110	2	Bearing-Axle, Rear	23	103-8864	4	Zerk 65° 3/16
5	103-6158	1	Bracket-Pivot, Lift	24	104-8300	8	Nut-Nyloc 5/16-18 Flg
6	12-3270	2	Screw-HWH 1/4-20 X 1/2 Taptite	25	104-8301	2	Nut-Nyloc 3/8-16 Flg
7	103-6165	1	Cover-Handle	26	109-2456-03	1	Rod-Torque
8	109-5974	1	Shield-Rear	27	109-2458	1	Rod-Shield
9	103-6441	2	Cover-Gear	28	109-2833	1	LH Bearing Support ASM
10	103-6445	2	Gear-Driven	29	109-2834	1	RH Bearing Support ASM
11	103-9975	2	Asm, Rear Wheel & Tire	30	321-10	1	Screw-HH 1/4-20 X 1 3/4
12	103-7654	2	Seal	31	3230-1	6	Bolt-Carriage 5/16-18 X 3/4
13	103-7659	2	Spring	32	3230-2	2	Bolt-Carriage 5/16-18 X 1
16	103-7897	1	Spring	33	3296-56	1	Nut-Nyloc 1/4-20 Thin
17	103-8225	1	Asm, Rear Adjuster	34	112-8707	2	10 Inch Wheel ASM

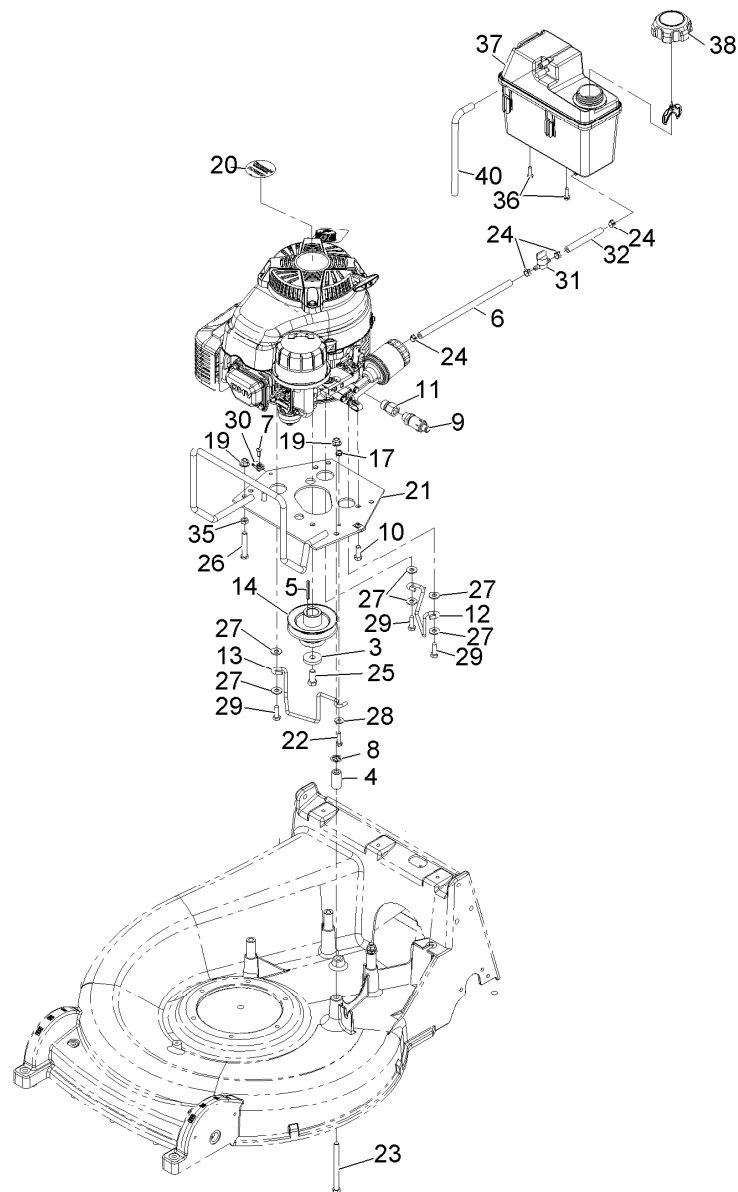

Engine Assembly

Ref.	Part Number	Qty.	Description	Ref.	Part Number	Qty.	Description
3	1-543610	1	Washer-Clutch	22	321-6	1	Screw-HH
4	116-1182	4	Spacer	23	323-23	4	Screw-HH
5	7-0036	1	Key-Square	24	2412-98	4	Clamp-Hose
6	109-0294	1	Hose-Fuel	25	3212-4	1	Screw-HH ■
7	63-8590	2	Screw	26	323-12	1	Screw-HH
8	78-7170	4	Ring-Retaining	27	3256-3	6	Washer-Flat
9	92-6877	1	Valve-Drain, Oil ●	28	3290-456	1	Washer-Belleville
10	95-1726	4	Screw-Taptite	29	33114-025	3	Screw-HH ■
11	103-1966	1	Adapter ●	30	107069	2	Clip
12	116-0860	1	Guide-Belt, Rear	31	1-603770	1	Valve-Fuel
13	116-0859	1	Guide-Belt, Front	32	109-0295	1	Hose-Fuel
14	116-0822	1	Sheave-Drive ▲	35	3218-3	1	Nut-Jam
17	104-7201	1	Nut-HF	36	46-8091	2	Screw-HWH
19	104-8301	5	Nut-Flange, NI	37	114-0280	1	Tank-Fuel
20	109-6528	1	Decal, Recoil Kai	38	109-6776	1	Cap-Ratchet, Tethered
21	116-0972-03	1	Plate-Engine	40	115-0962	1	Hose-Vent, Canister

● Use a Teflon Pipe Sealant or equivalent on threads.

■ Use Pro-Lock, Nut Type (P/N 1-840022, .5ml tube) on threads.

▲ Apply Mobil HTS grease (P/N 103-5217 1.5 oz packet) (or a food-grade anti-seize). See operator s manual for locations.

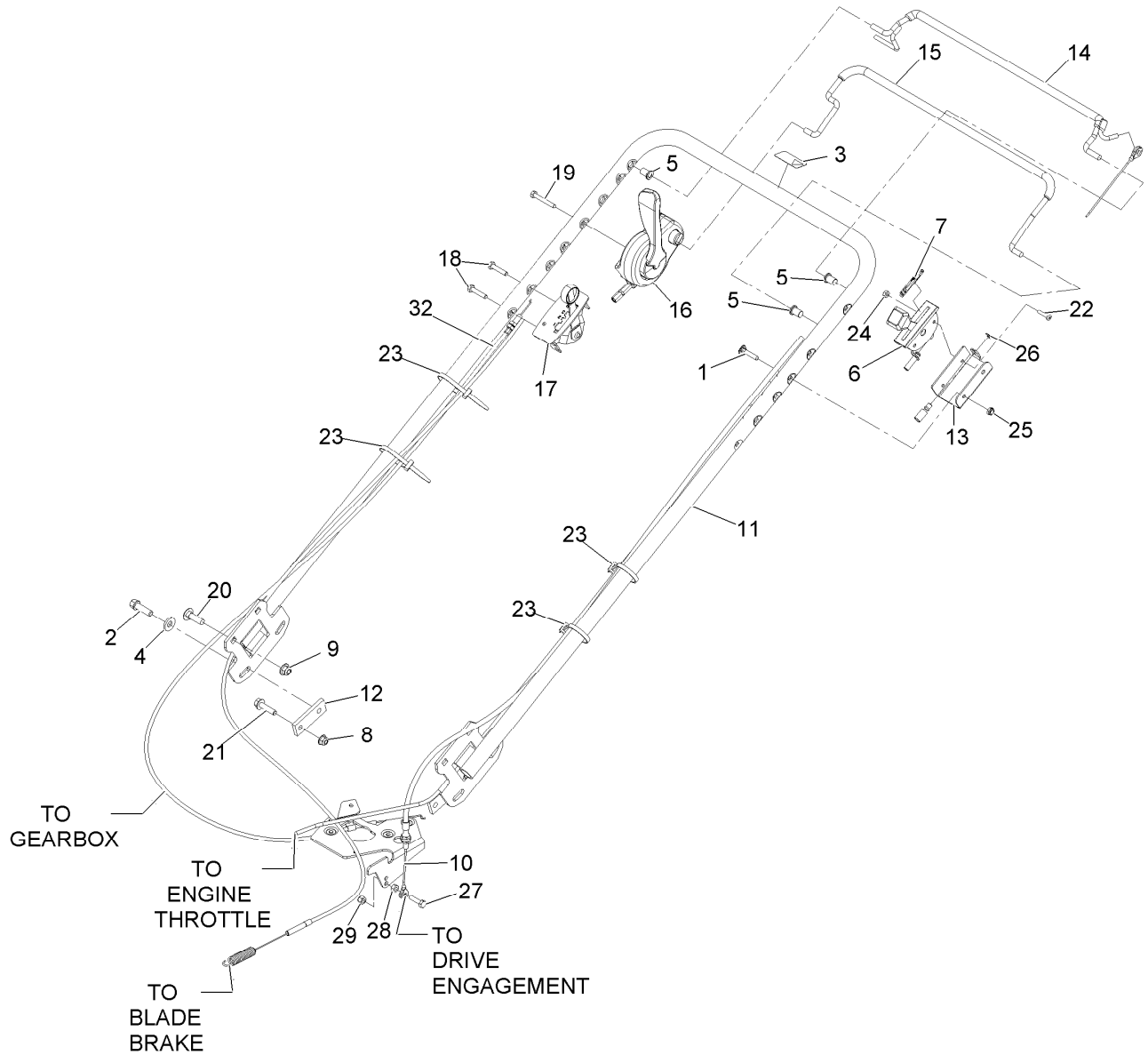

Handle Assembly

Ref.	Part Number	Qty.	Description	Ref.	Part Number	Qty.	Description
1	109-8144	2	Bolt-Handle	16	116-1079	1	Control-BBC
2	95-1727	2	Screw-Taptite	17	116-0504	1	Control-Shift
3	98-4387	1	Decal-Protection, Ear	18	321-8	2	Screw-HH
4	98-5975	2	Washer-Belleville	19	33113-045	1	Screw-HH
5	109-2713	3	Bushing	20	3231-25	2	Screw-CARR
6	103-6123	1	Control-Throttle	21	3234-36	2	Screw-HHF
7	103-6328	1	Decal-Throttle / Choke	22	3250-27	2	Screw-PPH
8	104-8300	2	Nut-Flange, NI	23	3290-378	4	Tie-Cable
9	104-8301	2	Nut-Flange, NI	24	3296-2	2	Nut-Lock, NI
10	109-2212	1	Cable-Traction	25	3296-56	2	Nut-Lock, NI
11	109-0472	1	Asm, Handle W/Decal	26	32151-86	1	E-Ring
12	109-2643-03	2	Nut-Handle	27	321-6	1	Screw-HH
13	109-2821-03	1	Bracket-Control	28	3217-5	1	Nut-Hex
14	116-0389	1	Traction Bail With Grip ASM	29	3296-42	1	Nut-Lock, NI
15	109-2826	1	Bail-BBC (With Grip)	32	109-4115	1	Cable-Shifter

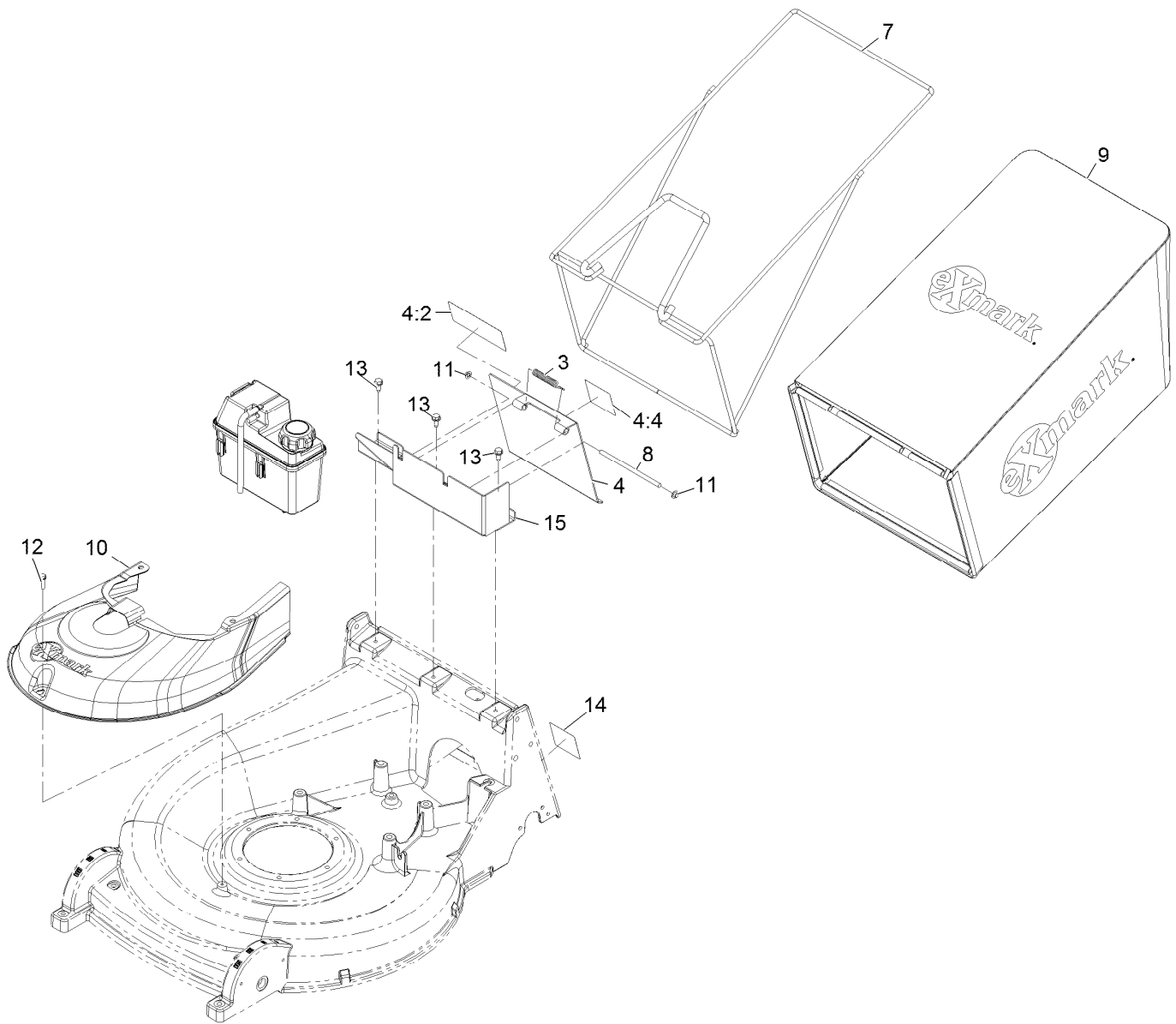

Discharge Door and Bag Assembly

Ref.	Part Number	Qty.	Description
3	99-5293	1	Spring
4	109-0072	1	Asm, Door W/Decal
4:2	104-8585	1	Decal-Warning
4:4	121-1449	1	Decal, Block Warning
7	109-2445-03	1	Frame-Bag
8	109-2453	1	Rod-Pivot, Door
9	109-2644	1	Bag, Debris
10	109-2645	1	Cover, Spindle
11	32112-11	2	Nut-Push 5/16
12	32144-86	1	Screw-HWH 1/4-20 X 1 Tf
13	32144-70	3	Screw-HWH 5/16-18 X 3/4 Tf
14	109-3756	1	Decal, Grease
15	109-9701-03	1	Bracket, Door/Tank Mount

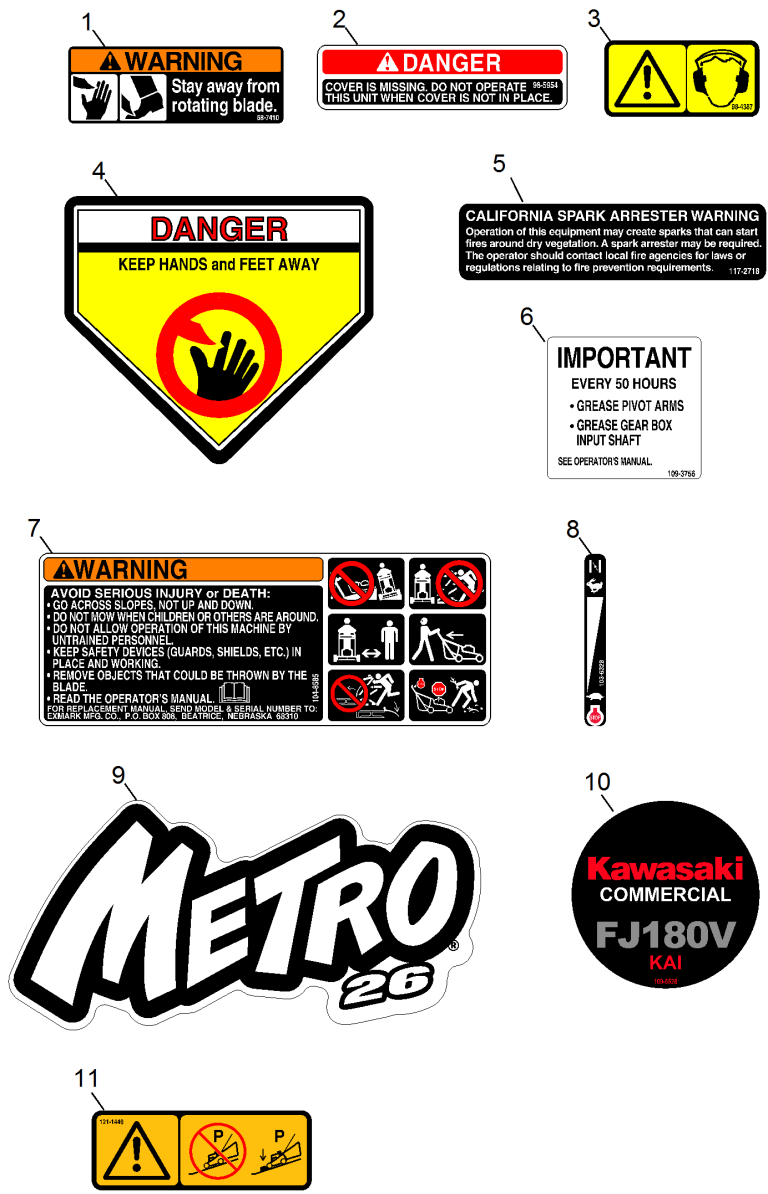

Decals

Ref.	Part Number	Qty.	Description
1	68-7410	1	Decal-Blade
2	98-5954	1	Decal-Cover, Missing
3	98-4387	1	Decal-Protection, Ear
4	43-8480	2	Decal-Danger
5	117-2718	1	Decal-Arrester, Spark
6	109-3756	1	Decal, Grease
7	104-8585	1	Decal-Warning
8	103-6328	1	Decal-Throttle / Choke
9	109-0046	1	Decal, Metro 26
10	109-6528	1	Decal, Recoil Kai
11	121-1449	1	Decal, Block Warning

Notes:

EXMARK ACCESSORIES AND OPTIONS*

MID-MOUNT RIDING ACCESSORIES AND OPTIONS

CUSTOM RIDE SEAT SUSPENSION SYSTEM	OPERATOR CONTROLLED DISCHARGE
FULL SUSPENSION SEAT	SUN SHADE
DECK LIFT ASSIST KIT	TRASH CONTAINER
HITCH KIT	TURF STRIPER
LIGHT KIT	ULTRA VAC COLLECTION SYSTEM
12V POWER PORT	ULTRA VAC QUICK DISPOSAL SYSTEM
MICRO-MULCH SYSTEM	

OUT-FRONT RIDING ACCESSORIES AND OPTIONS

CUSTOM RIDE SEAT SUSPENSION SYSTEM	SNOW BLADE
DUAL-TAIL WHEEL	SNOWBLOWER
FLOOR PAN EXTENDER	SUN SHADE
HITCH KIT	TRASH CONTAINER
LIGHT KIT	ULTRA VAC COLLECTION SYSTEM
MICRO-MULCH SYSTEM	ULTRA VAC QUICK DISPOSAL SYSTEM
ROLL OVER PROTECTION SYSTEM (ROPS)	WEATHER CAB

WALK-BEHIND ACCESSORIES AND OPTIONS

GRASS CATCHER	TURF STRIPER
MICRO-MULCH SYSTEM	STANDON

*Some accessories and options not available for some models.

Place Model No. and Serial No.
Label Here (Included in the Literature
Pack) or Fill in Below

Model No. _____

Serial No. _____

Date Purchased _____

Engine Model No. and Spec. No. _____

Engine Serial No. (E/No) _____

© 2012 Exmark Mfg. Co., Inc.
Industrial Park Box 808
Beatrice, NE 68310
All Rights Reserved

Part No. 4500-938 Rev. B
(402) 223-6300
Fax (402) 223-5489
Printed in the USA.

