

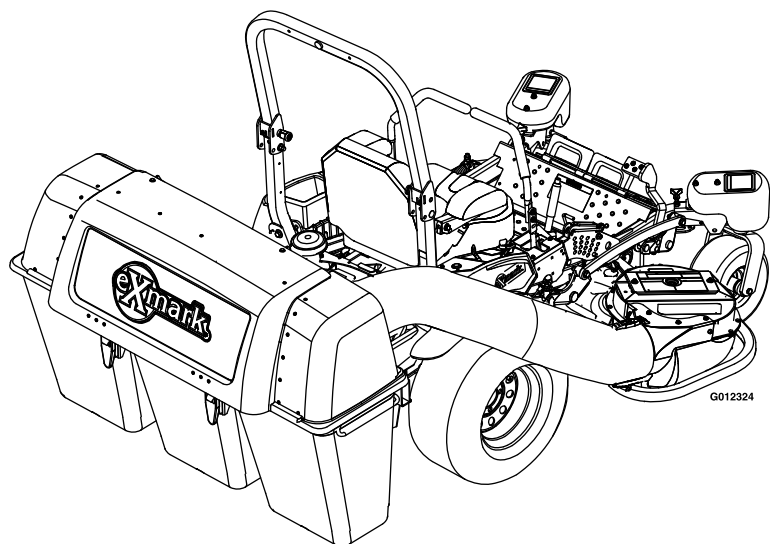

ULTRA VAC®

Model No. LZUV2B—Serial No. 31200000 and Up

Picture below may not reflect actual product.



Parts Manual

Ordering Replacement Parts

To order replacement parts, please supply the part number, the quantity, and the description of each part desired.

Understanding Reference Numbers

Each identified part in an illustration has a reference number. The reference number for a part also appears in the parts list, along with other information about the part.

This catalog uses two special reference number formats, one to indicate parts in a service assembly and another to indicate the quantity of a given part in an illustration.

Service Assembly Reference Numbers

Parts in service assemblies have reference numbers in the form a:b. The a represents the reference number of the entire service assembly and the b represents a sequential number unique to each part within the service assembly.

For example, a wheel assembly might be identified by reference number 6, the tire by 6:1, the valve by 6:2, and the wheel by 6:3. When you order the assembly identified by reference number 6, you receive all parts identified by reference numbers 6:1, 6:2, and 6:3. However, you may also order any part individually. Reference numbers of this type appear in illustration and in parts lists.

Reference Numbers Indicating Quantity

In an illustration, if a reference number indicates more than one part, the reference number has the form nX y. The n represents the quantity of the part, the X is the multiplication symbol, and the y represents the reference number.

For example, in an illustration, the reference number 2X 37 means that two of the parts identified by reference number 37 are indicated.

List of Abbreviations

AR: as required	HJ: hex jam	PTH: phillips truss head
ASM: assembly	HLH: hex lag head	PTO: power-take-off
BBC: blade brake control	HOC: height-of-cut	RH: right hand
BHTF: button head thread forming	HSBH: hex socket button head	ROPS: roll-over protection system
CARR: carriage	HSFH: hex socket flat head	RRB: rear roller brush
CCW: counter clockwise	HSH: hex socket head	SFH: slotted fillister head
CW: clockwise	HWH: hex washer head	SHH: slotted hex head
DEG: degrees	HWHTF: hex washer head thread forming	SHWH: slotted hex washer head
DPA: Dual Point Adjustment	HYD: hydraulic	SPH: slotted pan head
ECM: electronic control module	LH: left hand	SQH: square head
EXT: external	LPG: Liquid Propane Gas	SRH: slotted round head
FH: flat head	NI: nylon insert	STD: standard
GA: gauge	NPTF: national pipe thread fine	TAP: self tapping
HD: heavy-duty	PFH: phillips flat head	TTH: torx truss head
HF: hex flange	PPH: phillips pan head	
HH: hex head	PPHTF: phillips pan head thread forming	
HHF: hex head flange	PRH: phillips round head	
HHFTF: hex head flange thread forming		

Touch Up Paint

Exmark black touch up spray paint – gloss black.

Exmark red touch up paint (spray paint – P/N 1-850337 - .6 oz liquid bottle – P/N 103-9140).



If your Exmark dealer does not have the Exmark part in stock, Exmark will get the parts to the dealer the next business day or the part will be FREE Guaranteed!! (Some restrictions apply. See your participating Exmark Dealer for details.)

Contents

LZUV2B Assembly	4
Hood and Frame Assembly No. 109-5941	5
Hood Assembly No. 1-654597	6
Idler Assembly	7
Lower Tube Assembly No. 109-2043	8
Bag Support Frame Assembly No. 103-5166	9
Bag Assembly No. 116-0754	10
Blower Assembly No. 109-9832	11
Completing Kit No. 109-9622	13
Completing Kit No. 109-9623	14
Completing Kit No. 109-9624	15
Completing Kit No. 109-9625	16
Completing Kit No. 116-2084	17
Completing Kit No. 116-2085	18

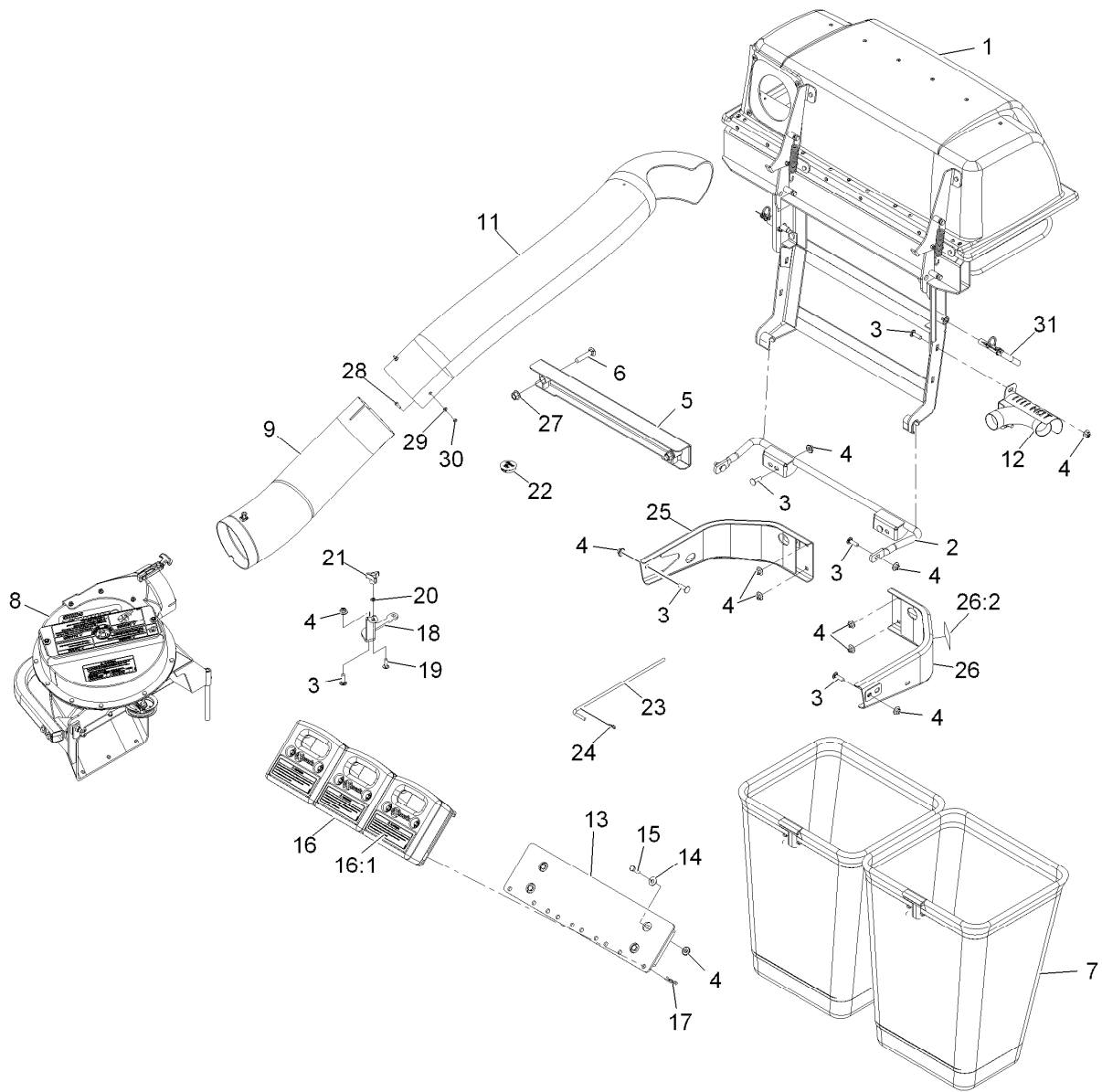

LZUV2B Assembly

Ref.	Part Number	Qty.	Description	Ref.	Part Number	Qty.	Description
1		1	ASM,Hood Uv 2-Bag ●	17	9335124	6	Hairpin-Cotter
2	109-9248	1	Mount-Bagger, Lower	18	116-0161-01	1	Bracket, Small Uv Belt Cover
3	3231-28	10	Bolt-Carriage 3/8-16 X 1 1/4	19	3230-2	1	Bolt-Carriage 5/16-18 X 1
4	109-6658	18	Nut-Nyloc 3/8-16 Flg	20	109-5667	1	Ring-Bolt Retaining
5	116-0473-03	1	Mount-Bagger, Upper	21	1-323385	1	Knob-3 Prong
6	3233-34	2	Bolt-Carriage 1/2-13 X 2 1/2	22	103-1279	1	Plug, Black Nylon 1.75
7	116-0754	2	Bag And Frame ASM	23	109-3458	1	Pin,Chute Pivot
8	109-9832	1	ASM, Blower Small - Svc Only	24	1-806003	1	Hairpin-Cotter
9	109-2043	1	Lower Tube ASM	25	116-0057-03	1	Bumper-RH
11	109-2036	1	Tube-Upper	26	116-0180	1	LH Bumper ASM
12	116-2804	1	Exhaust Diverter ASM	26:2	103-2076	1	Decal-Caution
13	116-1129-01	1	Wld, Mount Toeboard Weight	27	99-5107	2	Nut-Lock 1/2-13
14	3256-4	4	Washer-3/8 Std	28	32105-13	3	Screw-HWH #10-24 X 3/4
15	323-7	4	Screw-HH 3/8-16 X 1 1/4	29	3256-14	3	Washer-#10 Std
16	103-6363	3	ASM,Cast Weight	30	3296-2	3	Nut-Nyloc #10-24
16:1	103-6605	1	Decal,Weight	31	116-0458	2	Bagger Mount Pin ASM

● Not serviced separately

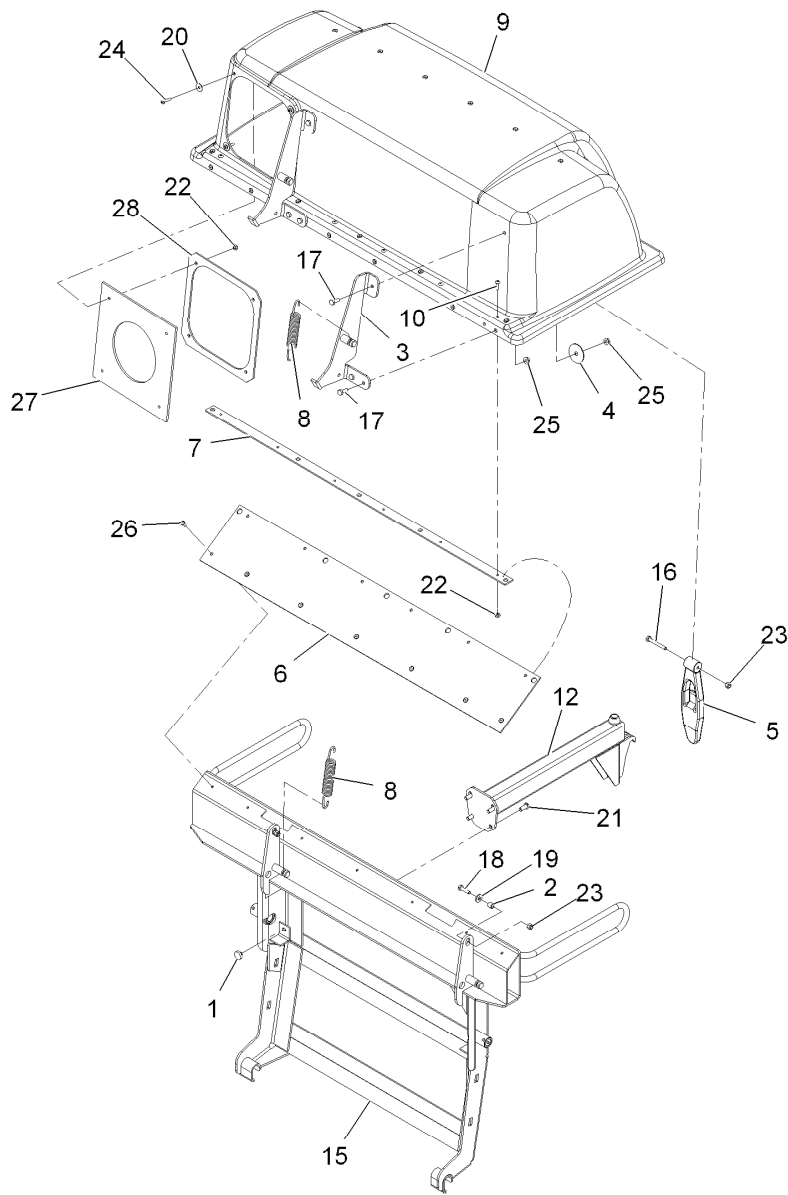

Hood and Frame Assembly No. 109-5941

<i>Ref.</i>	<i>Part Number</i>	<i>Qty.</i>	<i>Description</i>	<i>Ref.</i>	<i>Part Number</i>	<i>Qty.</i>	<i>Description</i>
1	1-513658	2	Bumper	17	321-4	6	Screw-HH 1/4-20 X 3/4
2	1-633545	2	Spacer	18	321-6	2	Screw-HH 1/4-20 X 1
3	1-652395-03	2	Hinge ASM	19	3256-2	2	Washer-1/4 Std
4	1-653036	2	Washer	20	3256-61	4	Washer
5	1-653403	1	Latch	21	3274-55	4	Screw-Button Head 5/16-18 X 3/4
6	1-653425	1	Seal	22	3296-2	10	Nut-Nyloc #10-24
7	1-653528-03	1	Plate-Backing	23	3296-42	3	Nut-Nyloc 1/4-20
8	1-653544	2	Spring-Extension	24	3250-27	4	Screw-PPH #10-24 X 7/8
9	1-654597	1	Asm, Hood	25	32128-33	6	Nut-Whizlock 1/4-20
10	1-803075	6	Screw-Truss Head #10-24 X 3/4	26	114439	7	Rivet
12	103-5166	1	Bag Support ASM	27	1-653561	1	Seal-Chute
15	109-8705-03	1	Frame-2-Bag, Uv	28	1-653598-03	1	Clamp-Seal
16	321-11	1	Screw-HH 1/4-20 X 2				

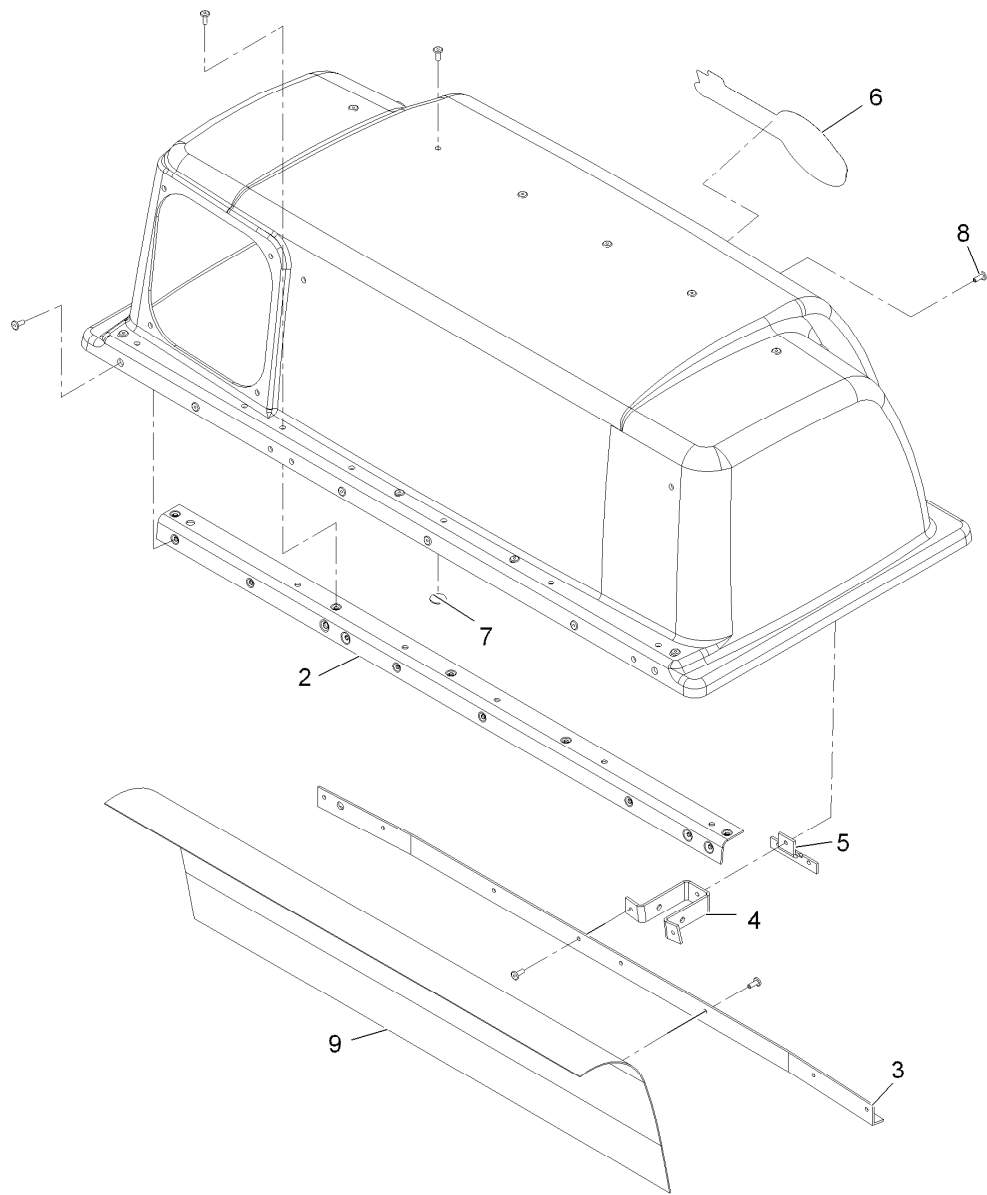

Hood Assembly No. 1-654597

<i>Ref.</i>	<i>Part Number</i>	<i>Qty.</i>	<i>Description</i>
2	1-653397-03	1	Stiffener-Bagger, Top
3	1-653400-03	1	Support-Screen
4	1-653519	1	Anchor-Latch
5	1-653535	1	Reinforcement-Latch
6	1-653546	1	Decal, Exmark Logo
7	3256-61	10	Washer
8	114439	31	Rivet
9	114967	1	Screen-Bagger

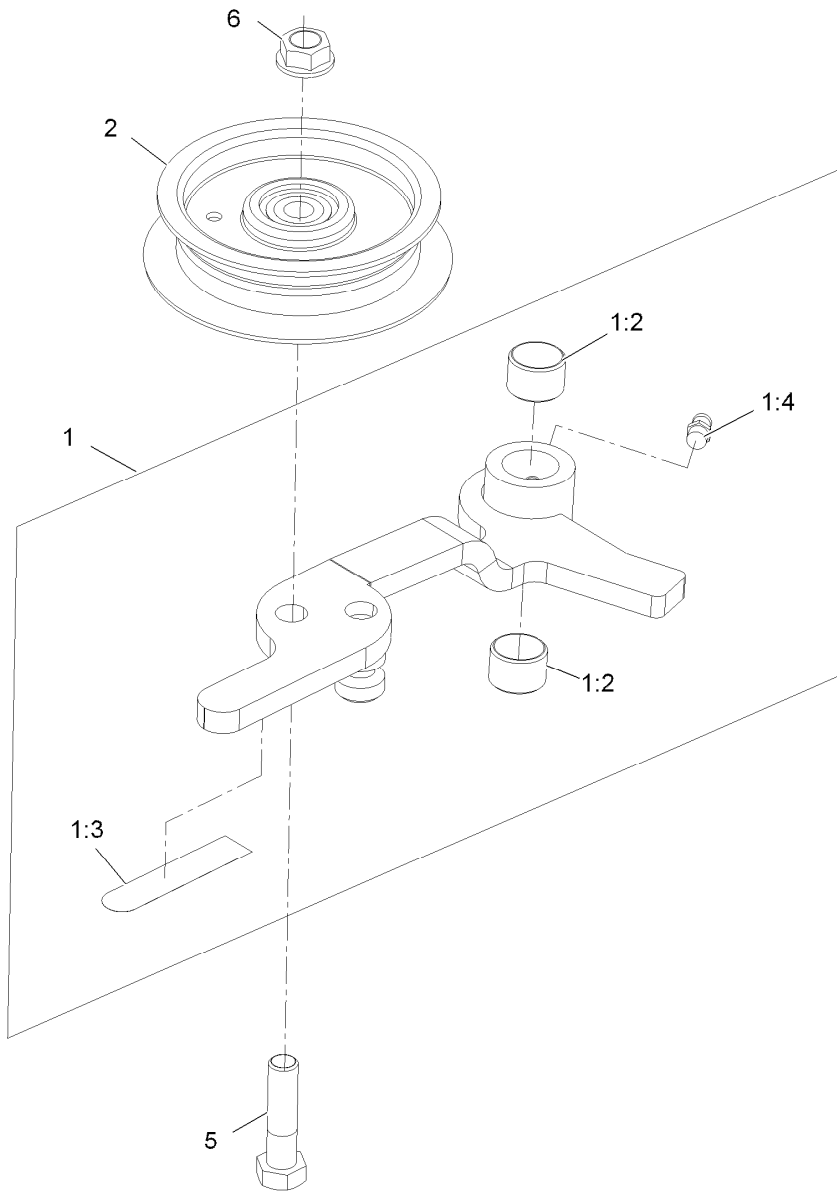

Idler Assembly

Ref.	Part Number	Qty.	Description
1	103-2876	1	ASM, Idler Arm - Service Only
1:2	1-653600	2	Bearing
1:3	1-653558	1	Decal-Hot Sheave
1:4	302-19	1	Zerk-1/4-28 Str
2	103-1103	1	Idler-Flat
5	323-8	1	Screw-HH 3/8-16 X 1 1/2
6	3290-357	1	Nut-Whizlock 3/8-16

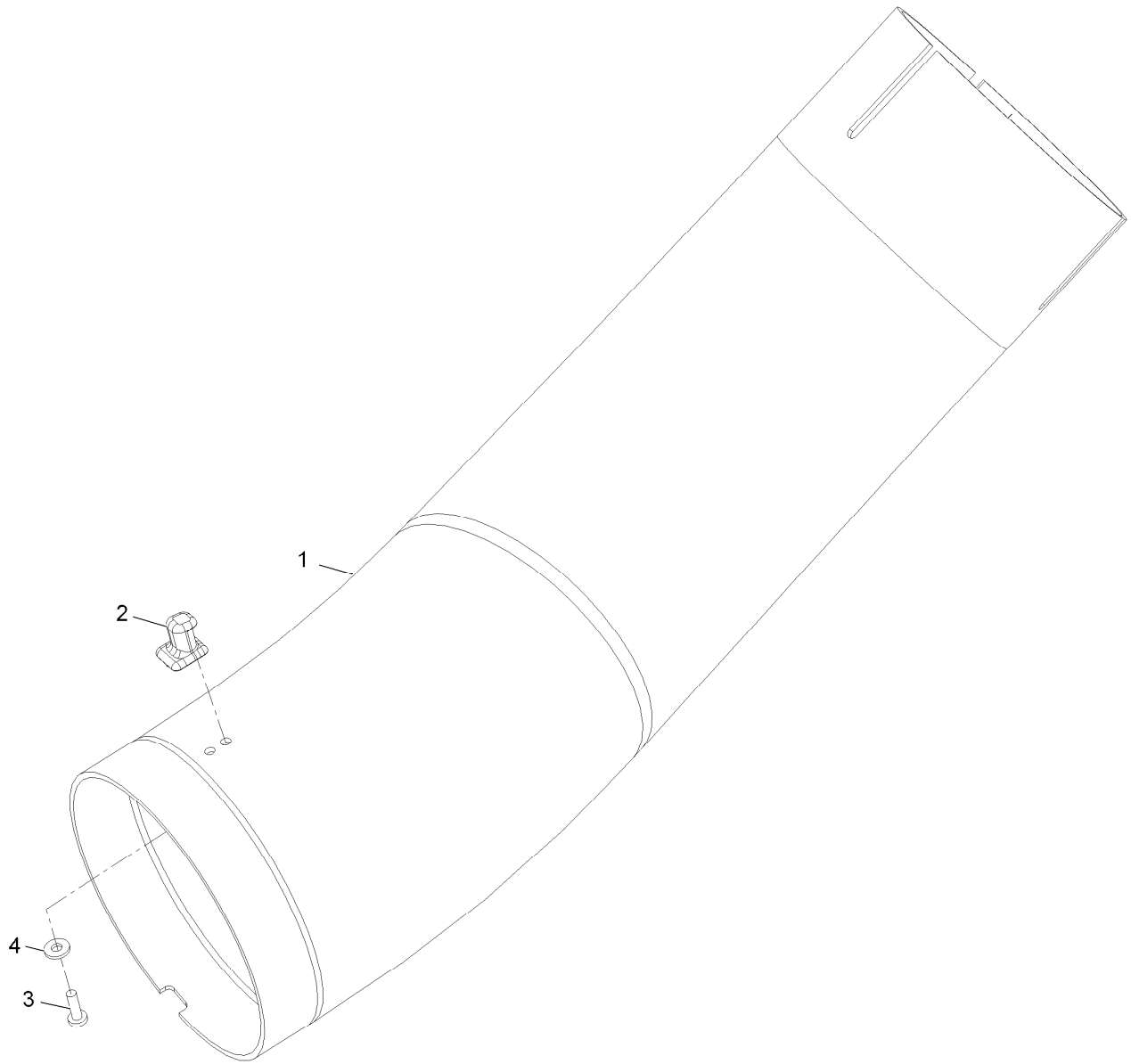

Lower Tube Assembly No. 109-2043

<i>Ref.</i>	<i>Part Number</i>	<i>Qty.</i>	<i>Description</i>
1	109-2038	1	Tube, Lower Short
2	103-4081	2	Latch-Keeper ●
3	3290-500	2	Screw-PPH #10-24 X 5/8
4	3256-14	2	Washer-#10 Std

● Kit No. 103-4188 - Contains catch, rubber latch, and mounting hardware

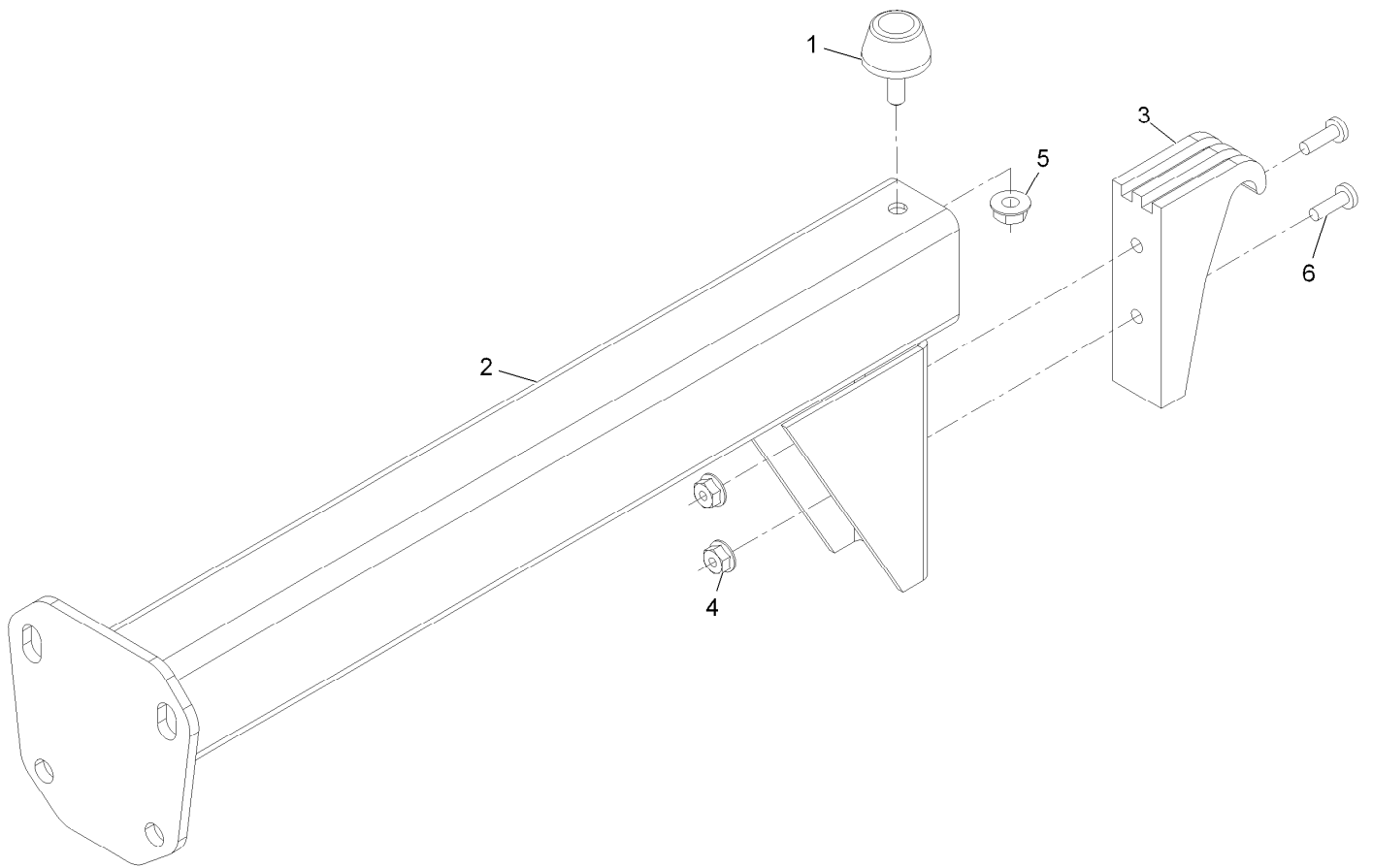

Bag Support Frame Assembly No. 103-5166

<i>Ref.</i>	<i>Part Number</i>	<i>Qty.</i>	<i>Description</i>
1	1-523420	1	Bumper
2	103-5124-03	1	Support-Bag
3	1-653404	1	Catch
4	3290-148	2	Nut-Whizlock #10-24
5	32128-33	1	Nut-Whizlock 1/4-20
6	3290-500	2	Screw-PPH #10-24 X 5/8

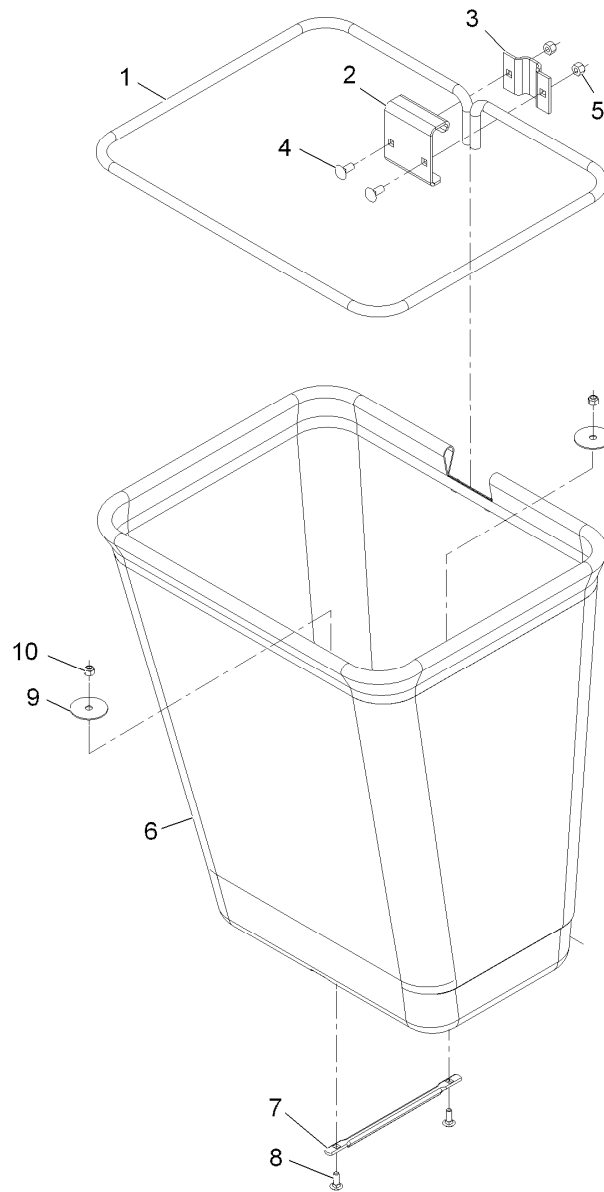

Bag Assembly No. 116-0754

Ref.	Part Number	Qty.	Description
1	1-653529-03	1	Frame-Bag
2	114973-03	1	Hanger-Bag
3	114974-03	1	Clamp
4	3230-1	2	Bolt-Carriage 5/16-18 X 3/4
5	3296-29	2	Nut-Nyloc 5/16-18
6	116-0757	1	Bag ASM
7	1-653566	1	Handle-Bag
8	3229-1	2	Bolt-Carriage 1/4-20 X 3/4
9	1-653036	2	Washer
10	3296-42	2	Nut-Nyloc 1/4-20

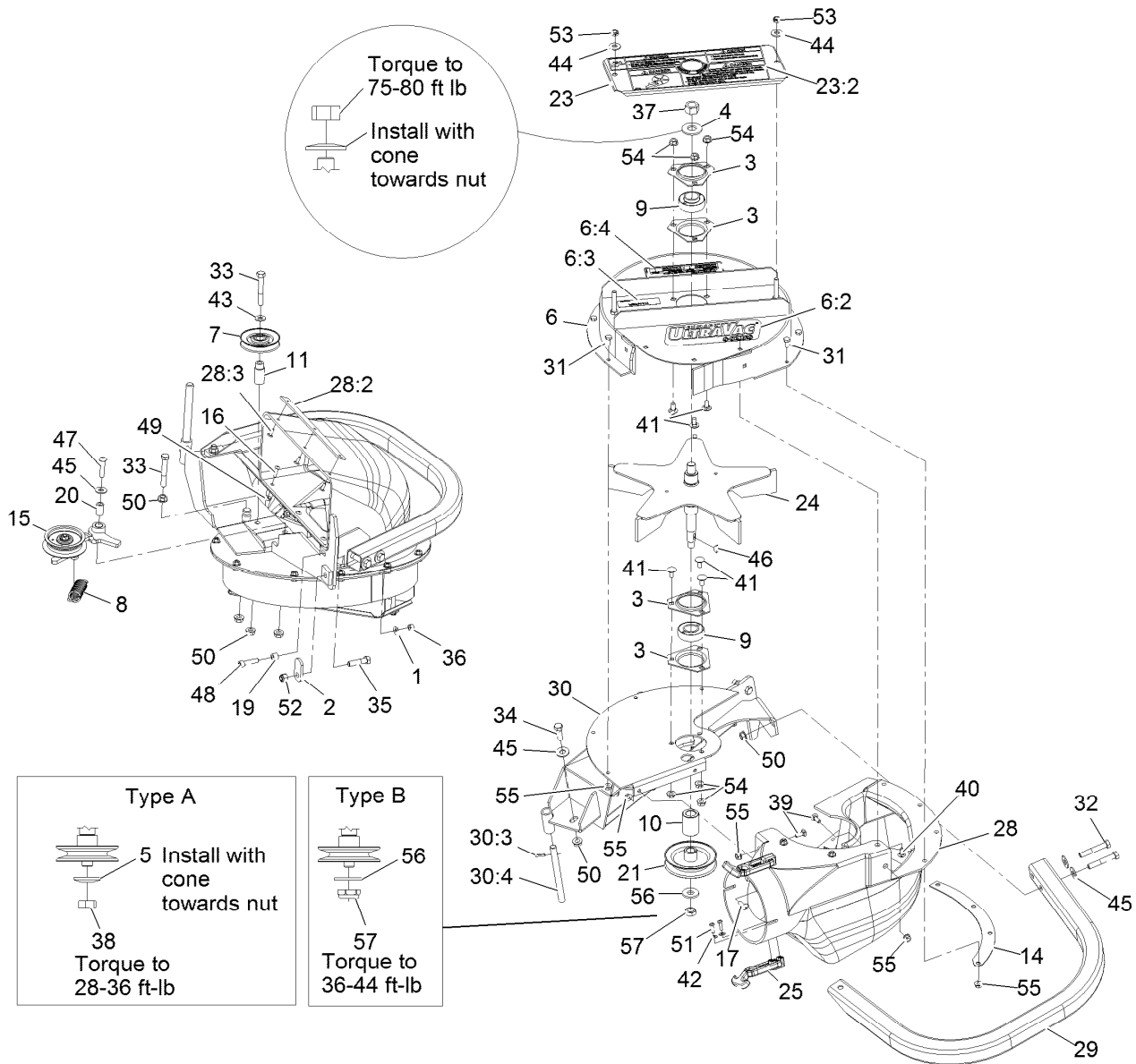

Blower Assembly No. 109-9832

Ref.	Part Number	Qty.	Description	Ref.	Part Number	Qty.	Description
1	1-303334	1	Washer-Spring Disc 5/16	16	1-803075	3	Screw-Truss Head #10-24 X 3/4
2	1-353054	1	Latch-Catcher, Grass	17	1-803076	2	Screw-PPH 1/4-20 X 3/4
3	1-513013	4	Housing-Flange	19	103-0126	1	Bushing
4	1-513208	1	Washer-Spring Disc 5/8	20	103-0130	1	Bushing-Pivot, Idler
5	1-513435	1	Washer-Spring Disc 1/2	21	103-1047	1	Sheave-Blower ♦
6	116-4817	1	ASM-Upper Housing Small	23	103-3585	1	ASM, Bearing Cover
6:2	116-4789	1	Decal-Ultra Vac S-Series	23:2	103-3508	1	Decal-Warning
6:3	98-5954	1	Decal-Cover, Missing	24	103-3815	1	Impeller
6:4	103-6604	1	Decal,Weight	25	103-4080	2	Latch-Rubber ▲
7	1-653322	1	Idler-Inside	28	109-1985	1	ASM,Blower Chute Lhp
8	1-653331	1	Spring	28:2	103-4752-03	1	Plate,Reinforcement Small
9	1-653346	2	Bearing ♦	28:3	114439	3	Rivet
10	1-653365	1	Spacer	29	109-1122-01	1	Bumper
11	1-653366	1	Spacer	30	109-9362-03	1	Weld, Frame Sm Blower
14	1-653596-03	1	Plate-Backing, Blower	30:3	1-806323	1	Rollpin 3/16 X 7/8
15		1	ASM, Idler ●	30:4	1-353050	1	Shaft-Catcher, Grass

● Not serviced separately

■ Use Pro-Lock retaining type, Part no. 1-840023 (.5cc tube) on threads.

▲ Kit No. 103-4188 - Contains catch, rubber latch, and mounting hardware

♦ Apply Mobil HTS grease (P/N 103-5217 1.5 oz packet) (or a food-grade anti-seize). See operator s manual for locations.

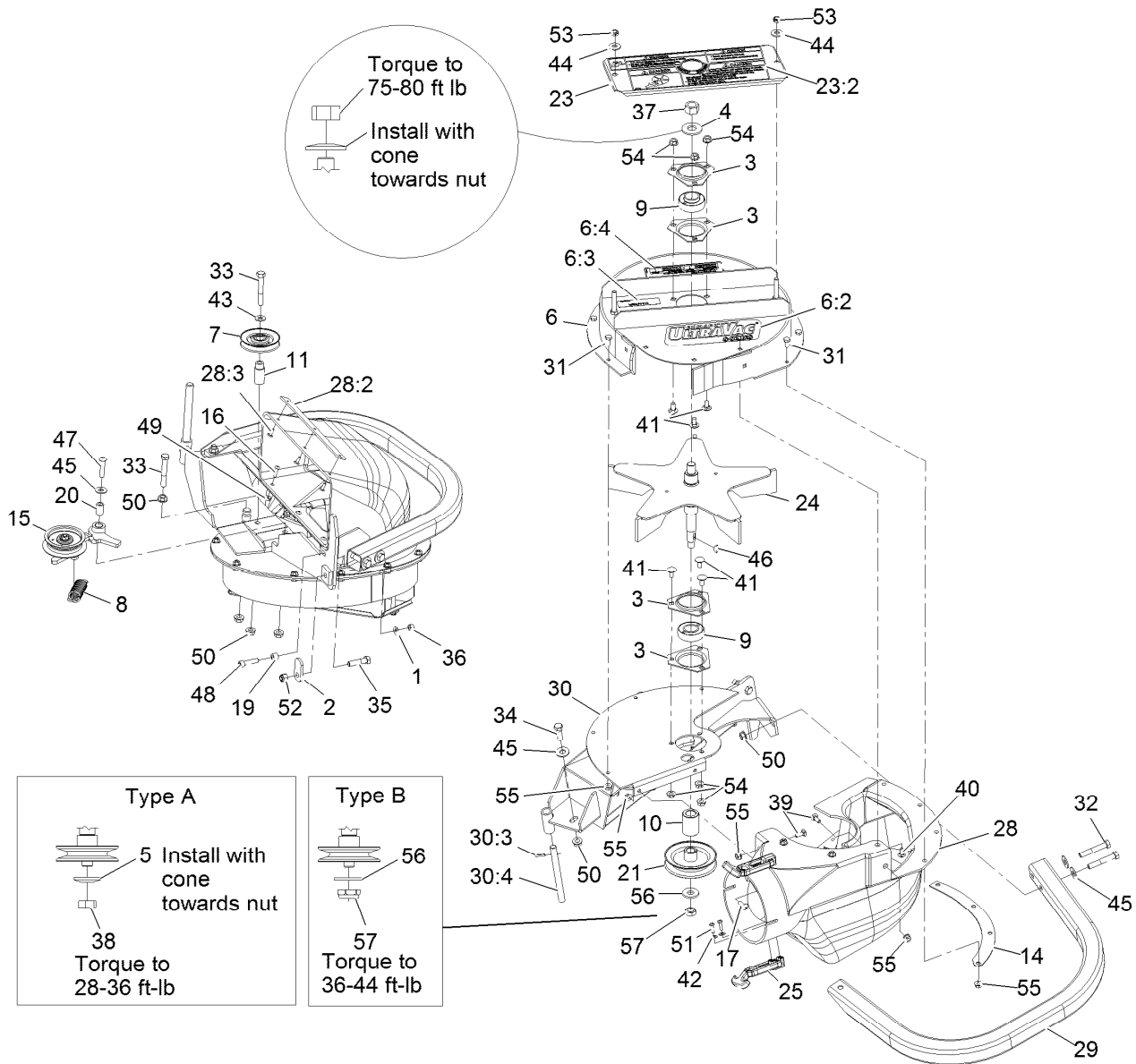

Blower Assembly No. 109-9832 (continued)

Ref.	Part Number	Qty.	Description	Ref.	Part Number	Qty.	Description
31	321-3	8	Screw-HH 1/4-20 X 5/8	45	3256-4	4	Washer-3/8 Std
32	323-11	2	Screw-HH 3/8-16 X 2 1/4	46	3257-32	1	Key-Woodruff 3/16 X 5/8
33	323-12	2	Screw-HH 3/8-16 X 2 1/2	47	3274-107	1	Screw-Button Head 3/8-16 X 1 3/4
34	323-7	1	Screw-HH 3/8-16 X 1 1/4	48	3274-18	1	Screw-Sh 5/16-18 X 1 1/4
35	323-8	1	Screw-HH 3/8-16 X 1 1/2	49	3290-148	3	Nut-Whizlock #10-24
36	3217-6	1	Nut-Hex 5/16-18	50	3290-357	7	Nut-Whizlock 3/8-16
37	3219-6	1	Nut-Hex 5/8-18	51	3290-500	4	Screw-PPH #10-24 X 5/8
38	3220-5	1	Nut-Jam 1/2-20 ■	52	3296-39	1	Nut-Nyloc 3/8-16
39	3229-1	2	Bolt-Carriage 1/4-20 X 3/4	53	3296-47	2	Nut-Nyloc 5/16-18 Thin
40	3229-11	3	Bolt-Carriage 1/4-20 X 5/8	54	32128-20	6	Nut-Whizlock 5/16-18
41	3230-18	6	Bolt-Carriage 5/16-18 X 5/8	55	32128-33	15	Nut-Whizlock 1/4-20
42	3256-14	4	Washer-#10 Std	56	3256-26	1	Washer-1/2 Sae
43	3256-24	1	Washer-3/8 Sae	57	3296-28	1	Nut-Lock, NI
44	3256-3	2	Washer-5/16 Std				

● Not serviced separately

■ Use Pro-Lock retaining type, Part no. 1-840023 (.5cc tube) on threads.

▲ Kit No. 103-4188 - Contains catch, rubber latch, and mounting hardware

◆ Apply Mobil HTS grease (P/N 103-5217 1.5 oz packet) (or a food-grade anti-seize). See operator s manual for locations.

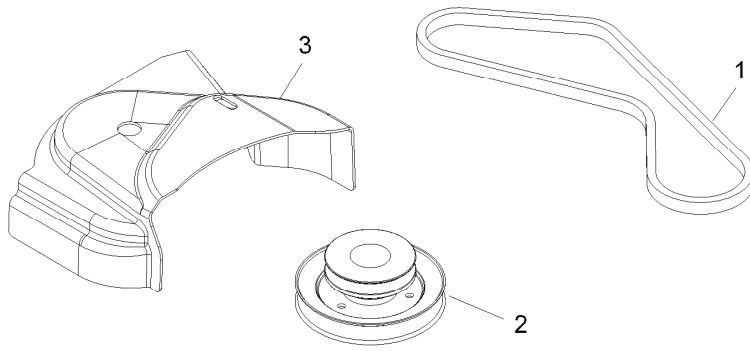

Completing kit fits all
Lazer Z Advantage Series (LZAS)
Serial Nos. 790,000-919,999
with 48 inch decks

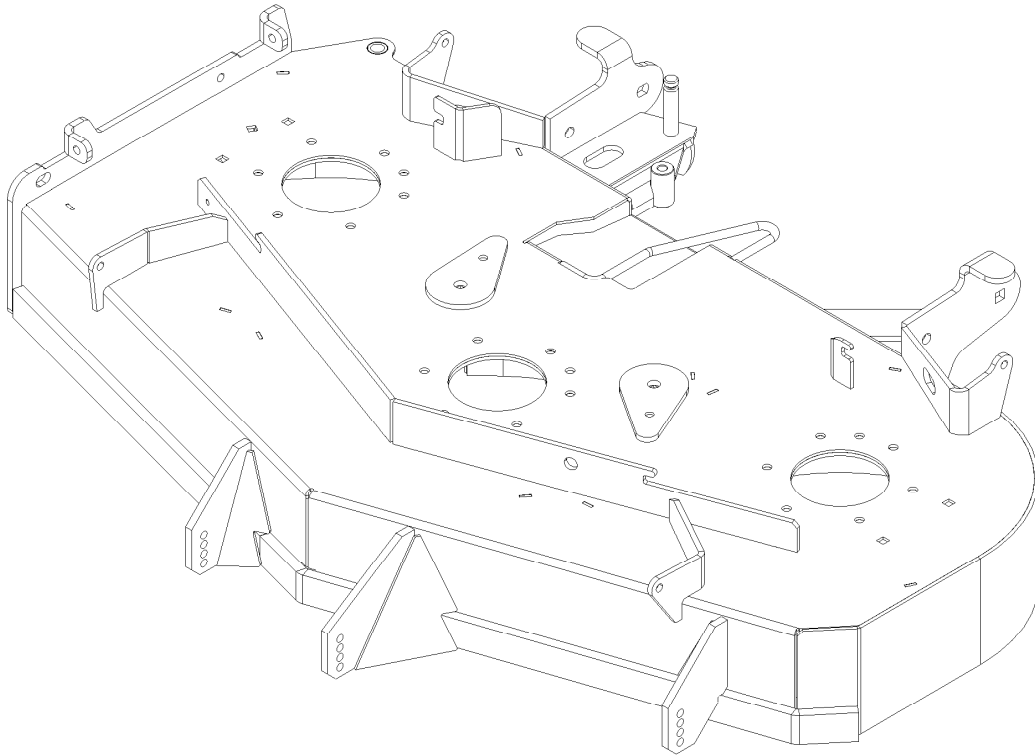

Completing Kit No. 109-9622

<i>Ref.</i>	<i>Part Number</i>	<i>Qty.</i>	<i>Description</i>
1	1-653333	1	Belt, Blower 48"dk
2	116-1649	1	Jackshaft,Uv Drive 484
3	109-9382	1	Cover,Belt Uv 48

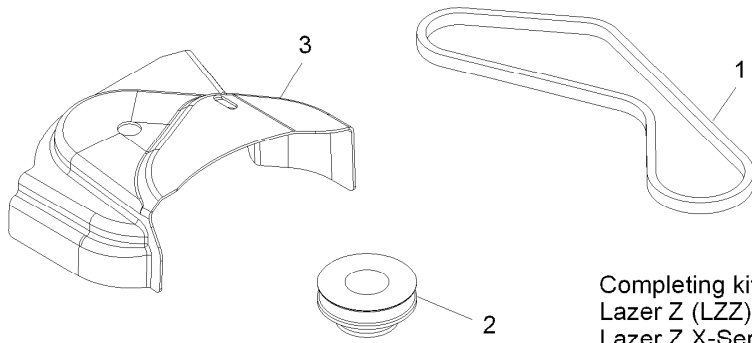

Completing kit fits all
 Lazer Z (LZZ) Serial Nos. 790,000-919,999 and
 Lazer Z X-Series (LZX) Serial Nos. 920,000 and Higher
 with 48 inch decks

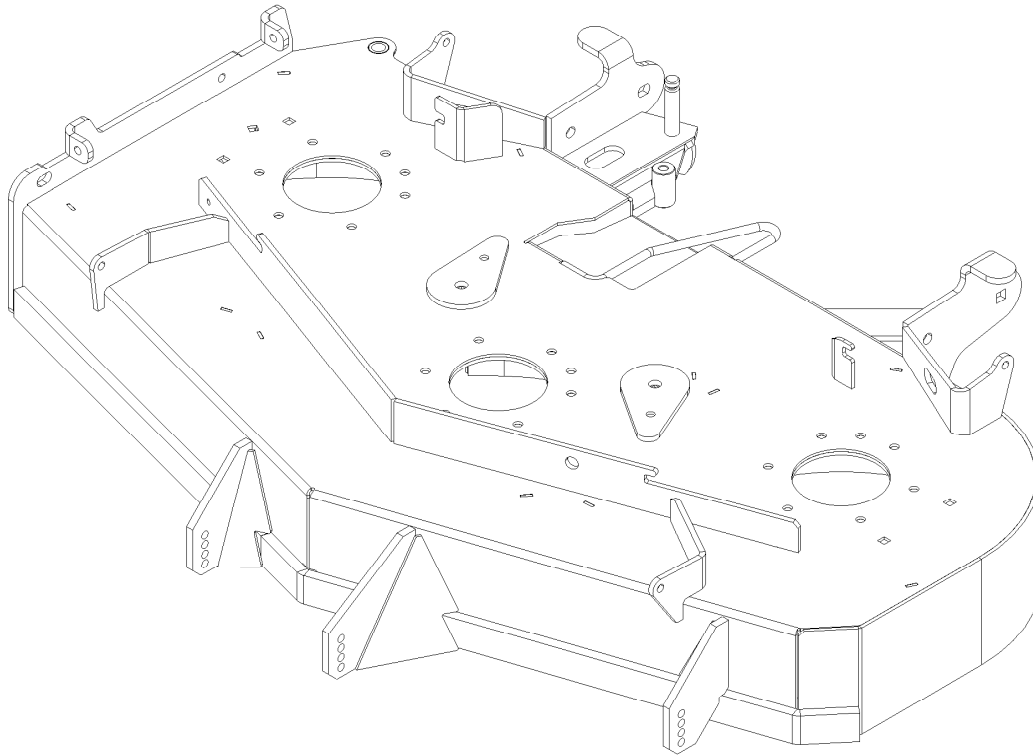

Completing Kit No. 109-9623

<i>Ref.</i>	<i>Part Number</i>	<i>Qty.</i>	<i>Description</i>
1	1-653333	1	Belt, Blower 48"dk
2	109-9631	1	Sheave, Drive Lzuv 486
3	109-9382	1	Cover, Belt Uv 48

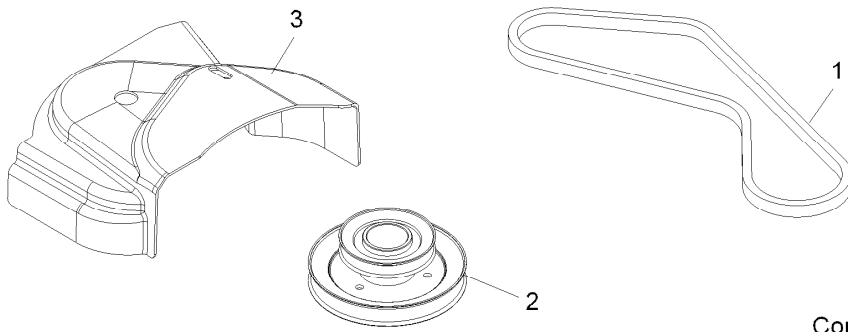

Completing kit fits all
Lazer Z Advantage Series (LZAS)
Serial Nos. 790,000-919,999
with 52 inch decks

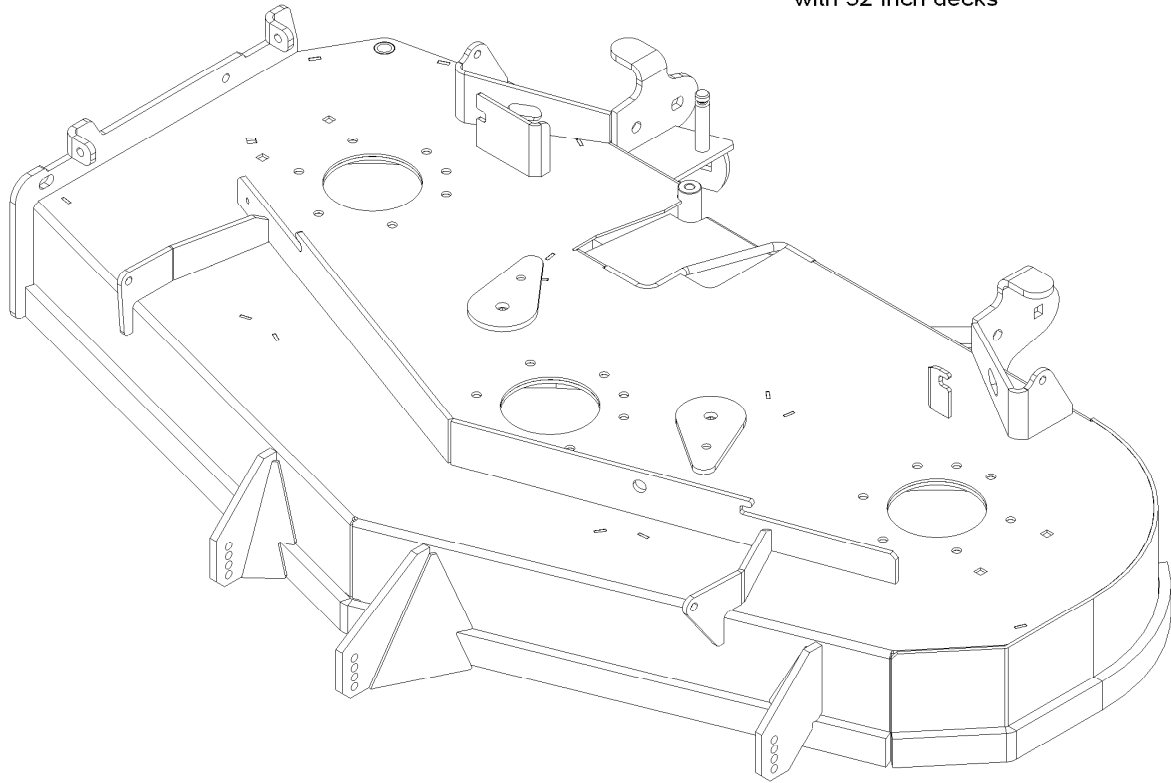

Completing Kit No. 109-9624

<i>Ref.</i>	<i>Part Number</i>	<i>Qty.</i>	<i>Description</i>
1	1-653438	1	Belt, Blower 52"deck
2	109-9632	1	Jackshaft,Uv Drive 524
3	109-8487	1	Cover,Belt Uv 52

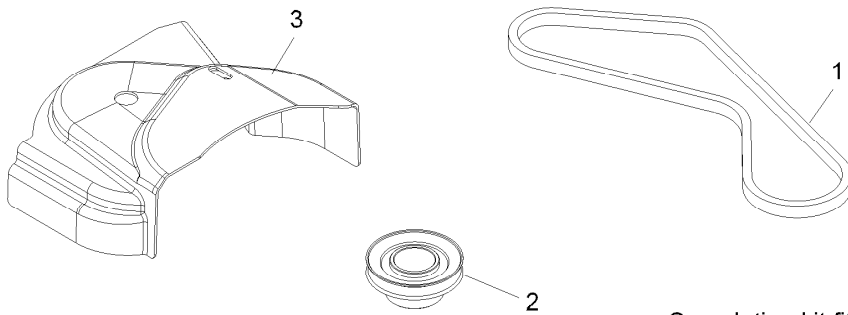

Completing kit fits all
 Lazer Z (LZZ) Serial Nos. 790,000-919,999 and
 Lazer Z X-Series (LZX) Serial Nos. 920,000
 and Higher with 52 inch decks

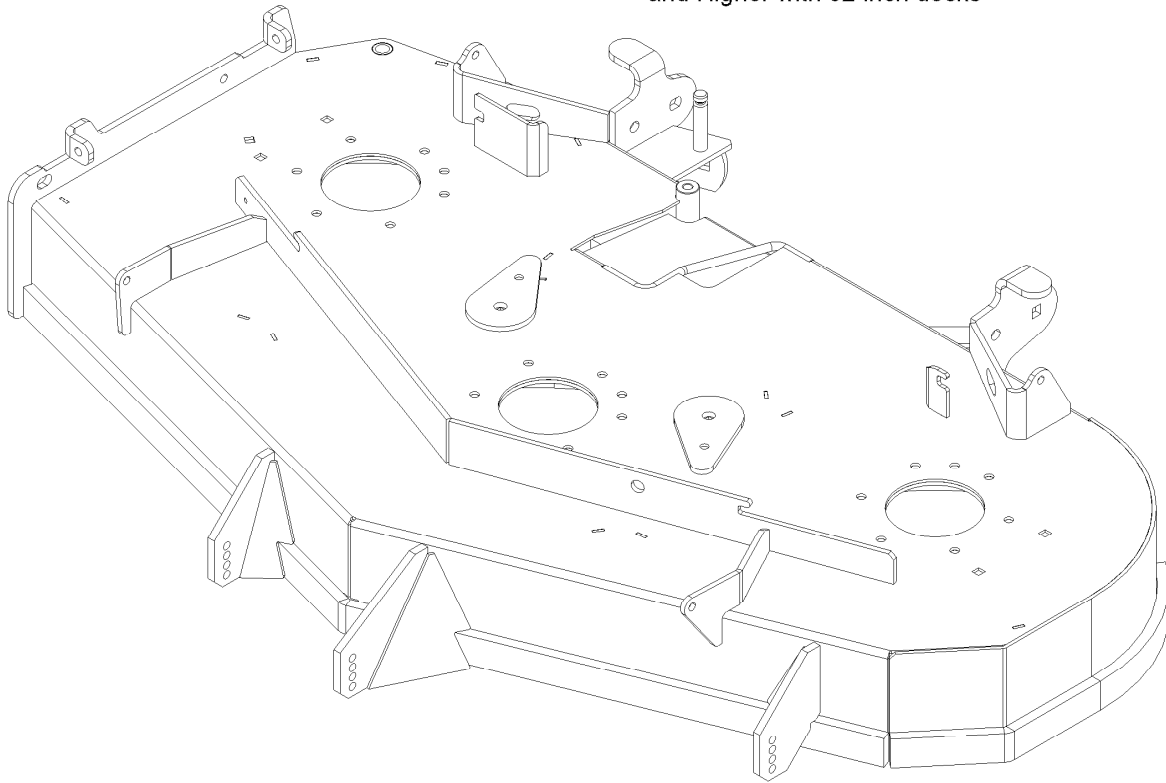

Completing Kit No. 109-9625

<i>Ref.</i>	<i>Part Number</i>	<i>Qty.</i>	<i>Description</i>
1	1-653438	1	Belt, Blower 52"deck
2	109-9633	1	Sheave,Drive Lzuv 526
3	109-8487	1	Cover,Belt Uv 52

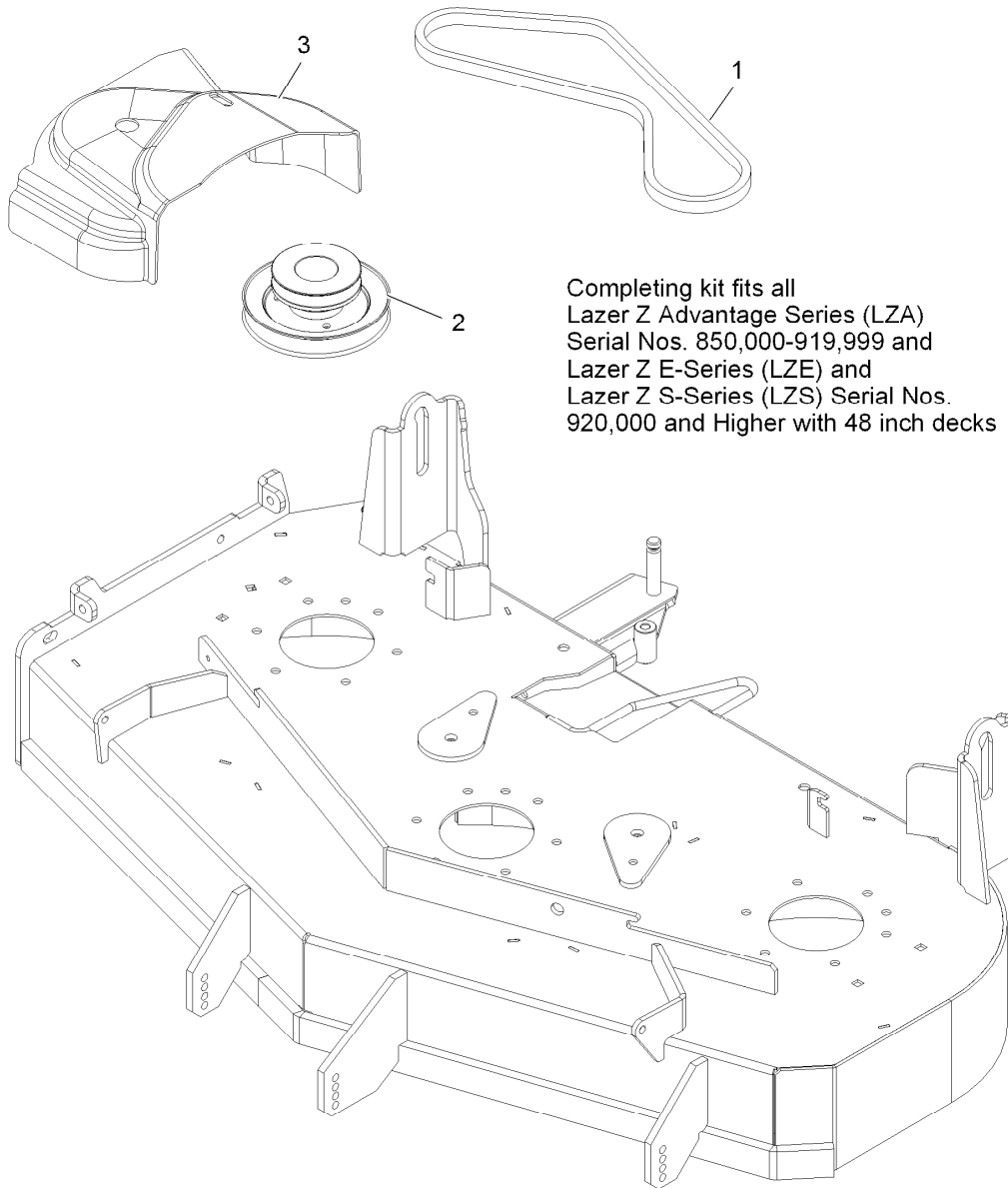

Completing kit fits all
 Lazer Z Advantage Series (LZA)
 Serial Nos. 850,000-919,999 and
 Lazer Z E-Series (LZE) and
 Lazer Z S-Series (LZS) Serial Nos.
 920,000 and Higher with 48 inch decks

Completing Kit No. 116-2084

<i>Ref.</i>	<i>Part Number</i>	<i>Qty.</i>	<i>Description</i>
1	1-653333	1	Belt, Blower 48"dk
2	116-2088	1	Jackshaft-Uv Drive, 484 Splined
3	109-9382	1	Cover,Belt Uv 48

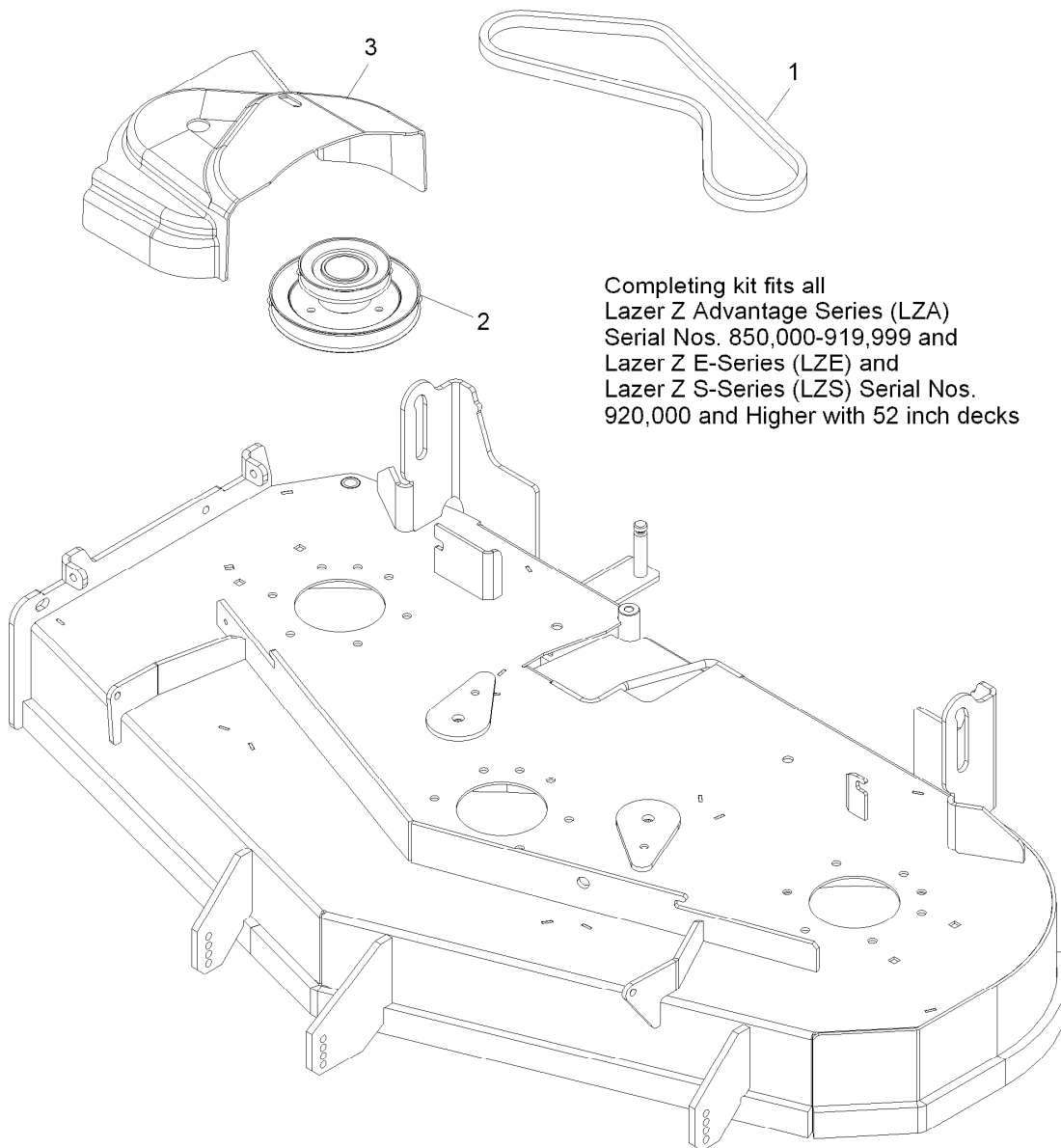

Completing kit fits all
 Lazer Z Advantage Series (LZA)
 Serial Nos. 850,000-919,999 and
 Lazer Z E-Series (LZE) and
 Lazer Z S-Series (LZS) Serial Nos.
 920,000 and Higher with 52 inch decks

Completing Kit No. 116-2085

<i>Ref.</i>	<i>Part Number</i>	<i>Qty.</i>	<i>Description</i>
1	1-653438	1	Belt, Blower 52"deck
2	116-2089	1	Jackshaft,Uv Drive 524 Splined
3	109-8487	1	Cover,Belt Uv 52

Notes:

EXMARK ACCESSORIES AND OPTIONS*

MID-MOUNT RIDING ACCESSORIES AND OPTIONS

CUSTOM RIDE SEAT SUSPENSION SYSTEM	OPERATOR CONTROLLED DISCHARGE
FULL SUSPENSION SEAT	SUN SHADE
DECK LIFT ASSIST KIT	TRASH CONTAINER
HITCH KIT	TURF STRIPER
LIGHT KIT	ULTRA VAC COLLECTION SYSTEM
12V POWER PORT	ULTRA VAC QUICK DISPOSAL SYSTEM
MICRO-MULCH SYSTEM	

OUT-FRONT RIDING ACCESSORIES AND OPTIONS

CUSTOM RIDE SEAT SUSPENSION SYSTEM	SNOW BLADE
DUAL-TAIL WHEEL	SNOWBLOWER
FLOOR PAN EXTENDER	SUN SHADE
HITCH KIT	TRASH CONTAINER
LIGHT KIT	ULTRA VAC COLLECTION SYSTEM
MICRO-MULCH SYSTEM	ULTRA VAC QUICK DISPOSAL SYSTEM
ROLL OVER PROTECTION SYSTEM (ROPS)	WEATHER CAB

WALK-BEHIND ACCESSORIES AND OPTIONS

GRASS CATCHER	TURF STRIPER
MICRO-MULCH SYSTEM	STANDON

*Some accessories and options not available for some models.

Place Model No. and Serial No.
Label Here (Included in the Literature
Pack) or Fill in Below

Model No. _____

Serial No. _____

Date Purchased _____

Engine Model No. and Spec. No. _____

Engine Serial No. (E/No) _____

© 2012 Exmark Mfg. Co., Inc.
Industrial Park Box 808
Beatrice, NE 68310
All Rights Reserved

Part No. 4501-058 Rev. A
(402) 223-6300
Fax (402) 223-5489
Printed in the USA.

