

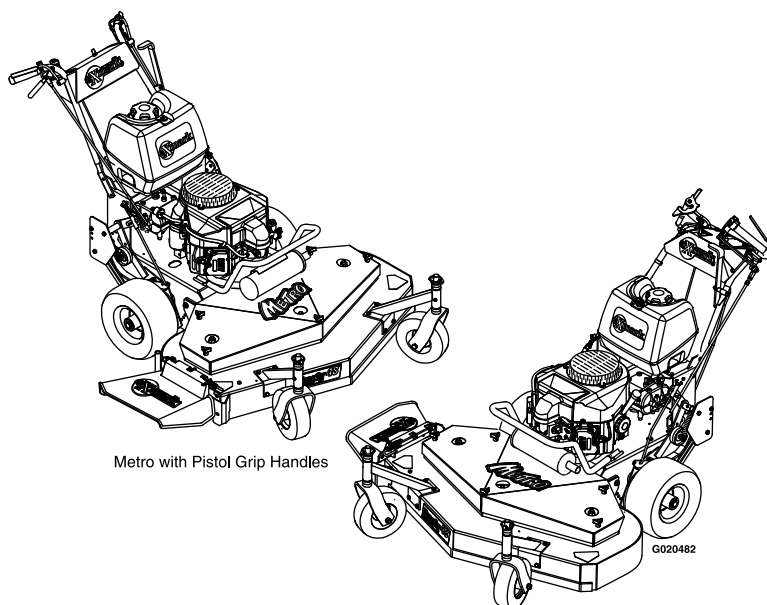

METRO®

Model No. MG481KA483CA—Serial No. 31400000 and Up

Picture below may not reflect actual product.



Metro with Pistol Grip Handles

Metro with ECS Handles

Parts Manual

Ordering Replacement Parts

To order replacement parts, please supply the part number, the quantity, and the description of each part desired.

Understanding Reference Numbers

Each identified part in an illustration has a reference number. The reference number for a part also appears in the parts list, along with other information about the part.

This catalog uses two special reference number formats, one to indicate parts in a service assembly and another to indicate the quantity of a given part in an illustration.

Service Assembly Reference Numbers

Parts in service assemblies have reference numbers in the form a:b. The a represents the reference number of the entire service assembly and the b represents a sequential number unique to each part within the service assembly.

For example, a wheel assembly might be identified by reference number 6, the tire by 6:1, the valve by 6:2, and the wheel by 6:3. When you order the assembly identified by reference number 6, you receive all parts identified by reference numbers 6:1, 6:2, and 6:3. However, you may also order any part individually. Reference numbers of this type appear in illustration and in parts lists.

Reference Numbers Indicating Quantity

In an illustration, if a reference number indicates more than one part, the reference number has the form nX y. The n represents the quantity of the part, the X is the multiplication symbol, and the y represents the reference number.

For example, in an illustration, the reference number 2X 37 means that two of the parts identified by reference number 37 are indicated.

List of Abbreviations

AR: as required	HJ: hex jam	PRH: phillips round head
ASM: assembly	HLH: hex lag head	PTH: phillips truss head
BBC: blade brake control	HOC: height-of-cut	PTO: power-take-off
BHTF: button head thread forming	HSBH: hex socket button head	RH: right hand
CARR: carriage	HSFH: hex socket flat head	ROPS: roll-over protection system
CCW: counter clockwise	HSH: hex socket head	RRB: rear roller brush
CW: clockwise	HWH: hex washer head	SFH: slotted fillister head
DEG: degrees	HWHTF: hex washer head thread forming	SHH: slotted hex head
DPA: Dual Point Adjustment	HYD: hydraulic	SHWH: slotted hex washer head
ECM: electronic control module	LH: left hand	SPH: slotted pan head
EXT: external	LP: Liquefied Petroleum Gas	SQH: square head
FH: flat head	LPG: Liquefied Petroleum Gas	SRH: slotted round head
GA: gauge	NI: nylon insert	STD: standard
HD: heavy-duty	NPTF: national pipe thread fine	TAP: self tapping
HF: hex flange	PFH: phillips flat head	TTH: torx truss head
HH: hex head	PPH: phillips pan head	
HHF: hex head flange	PPHTF: phillips pan head thread forming	
HHFTF: hex head flange thread forming		

Touch Up Paint

Exmark black touch up spray paint – gloss black.

Exmark red touch up paint (spray paint – P/N 1-850337 - .6 oz liquid bottle – P/N 103-9140).



If your Exmark dealer does not have the Exmark part in stock, Exmark will get the parts to the dealer the next business day or the part will be FREE Guaranteed!! (Some restrictions apply. See your participating Exmark Dealer for details.)

Contents

Mower Deck Assembly 4
Engine Deck Assembly 6
Engine Deck Assembly - (cont.) 8
ECS Upper Handle and Controls 10
Fuel Tank Assembly 12
Decals 13

Mower Deck Assembly (continued)

Ref.	Part Number	Qty.	Description	Ref.	Part Number	Qty.	Description
1	109-2601	1	Deck (116-0617-01)W/Dcls And Dogleg	45	1-303334	1	Washer-Spring Disc 5/16
2	116-1729-01	1	Wld, Dogleg Baffle	46	103-3600	1	Idler Arm ASM
3	322-2	3	Screw-HH 5/16-18 X 5/8	47	116-3515	1	Screw,HH Special 5/16-18 X 1.25
4	32128-20	11	Nut-Whizlock 5/16-18	48	302-19	1	Zerk-1/4-28 Str
5	3296-29	1	Nut-Nyloc 5/16-18	50	323-20	1	Screw-HH 3/8-16 X 3-1/4
6	323-7	18	Screw-HH 3/8-16 X 1 1/4	51	3296-56	1	Nut-Nyloc 1/4-20 Thin
7	3290-357	17	Nut-Whizlock 3/8-16	52	109-5151	1	Deflector-Discharge
8	98-5975	12	Washer-Spring Disc 3/8	53	1-403179	1	Tube-Pivot
9	1-808280	1	Pin-Clevis 5/16 X 1 49/64	54	3256-3	1	Washer-5/16 Std
10	1-303105	1	Yoke-Adjustable	55	1-323714	1	Rod-Brake
11	109-0977	2	Pulley,Idler 5"	56	1-324372	1	Pad And Spring ASM
12	32151-103	1	E-Ring	57	3256-23	1	Washer-5/16 Sae
13	103-6583	3	Blade, 16.25 Notched	58	116-3626	1	Pulley-Idler
13	103-6581	3	Blade, 16.25 Mulching ■	59	1-403174	1	Drive Belt (Main Deck) 48"
13	103-6738	3	Blade, Low Lift	60	1-323746	1	Spacer-Flanged
13	103-1577	3	Blade, 16.25 Solid	61	1-413113	2	Bushing-Idler
13	116-5178	3	Blade, Extreme	62	109-8854	1	Pin-Chute
14	1-323303	1	Arm-Assist, Linkage	63	1-323071	1	Spring-Extension
15	3246-18	3	Setscrew-5/16-18 X 3/8 ●	64	103-1330	3	Guard-Bearing Top ▲
16	323-13	2	Screw-HH 3/8-16 X 2 3/4	65	103-2281	2	Caster/Mount, Complete
17	3296-42	2	Nut-Nyloc 1/4-20	66	103-2296	2	Caster Whl Support W/Bearings, Weighted
18	1-513810	4	Bushing-Flanged	67	103-2297-01	2	Caster Whl Support Wldmnt, Weighted
19	103-8387	3	Asm, Cutter Housing Complete	68	302-52	2	Zerk-1/8-27 Str
20	103-8280	3	Asm, Cutter Housing W/Bearings ▲	69	1-303514	4	Bearing-Flanged
21	302-61	2	Zerk-45° 1/4-28	70	1-303314	8	Spacer-Caster
22	103-2535	3	Spacer-Guard Bottom	71	103-1236	2	Caster Wheel Assembly
23	1-513809	2	Bearing	72	116-7942-01	2	Fork-Caster
24	702809	1	Screw-HH	73	321-4	2	Screw-HH 1/4-20 X 3/4
25	1-323529	3	Tube-Spindle, Short ▲	74	1-323748	1	Ring-Push On
26	32120-35	1	E-Ring	75	1-323417	5	Washer-Belt Shield
27	3296-39	18	Nut-Nyloc 3/8-16	76	323-4	8	Screw-HH 3/8-16 X 3/4
28	1-807267	3	Key-Machine 1/4 X 3/16 X 1 1/4	77	325-20	2	Screw-HH 1/2-13 X 6
29	1-403183	3	Sheave ▲	78	3217-9	2	Nut-Hex 1/2-13
30	1-513208	3	Washer-Spring Disc 5/8	79	3253-7	2	Washer-Lock 1/2
31	1-800861	3	Screw-Cap, HH	80	1-513338	2	Washer
32	1-323539	12	Spacer-Blade Drive	81	1-809020	2	Pin
33	1-323339	3	Washer	82	1-303537	2	Stud-Shield, Belt (Short)
34	1-322235	1	Arm-Assist	83	1-303536	3	Stud-Shield, Belt (Long)
35	3219-6	3	Nut-Hex 5/8-18	84	1-323385	5	Knob-3 Prong
36	1-303434	1	Bushing-Engagement	85	116-2707	1	Shield (1-402100-01)W/Decals 48
37	1-303348	1	Eyebolt-Thread, LH	86	1-403188	1	Spacer
38	1-303236	1	Body-Turnbuckle	87	323-8	8	Screw-HH 3/8-16 X 1 1/2
39	1-303238	1	Eyebolt-Thread, RH	88	1-513547	2	Spacer
40	1-323747	1	Spring-Compression	89	103-2171	2	Kit,Semi-Pneumatic Wheel Replacement
41	1-806003	3	Hairpin-Cotter	90	116-0962	1	Spring, Torsion
42	1-303352	1	Washer-Spindle	91	104-8301	2	Nut-Nyloc 3/8-16 Flg
43	322-10	1	Screw-HH 5/16-18 X 2				
44	1-323729	2	Sleeve-Bearing				

● Use Pro-Lock, Nut Type (P/N 1-840022, .5ml tube) on threads.

■ Requires installation of mulch kit for proper mulching. See your Exmark dealer for details.

▲ Apply Mobil HTS grease (P/N 103-5217 1.5 oz packet) (or a food-grade anti-seize). See operator s manual for locations.

Engine Deck Assembly

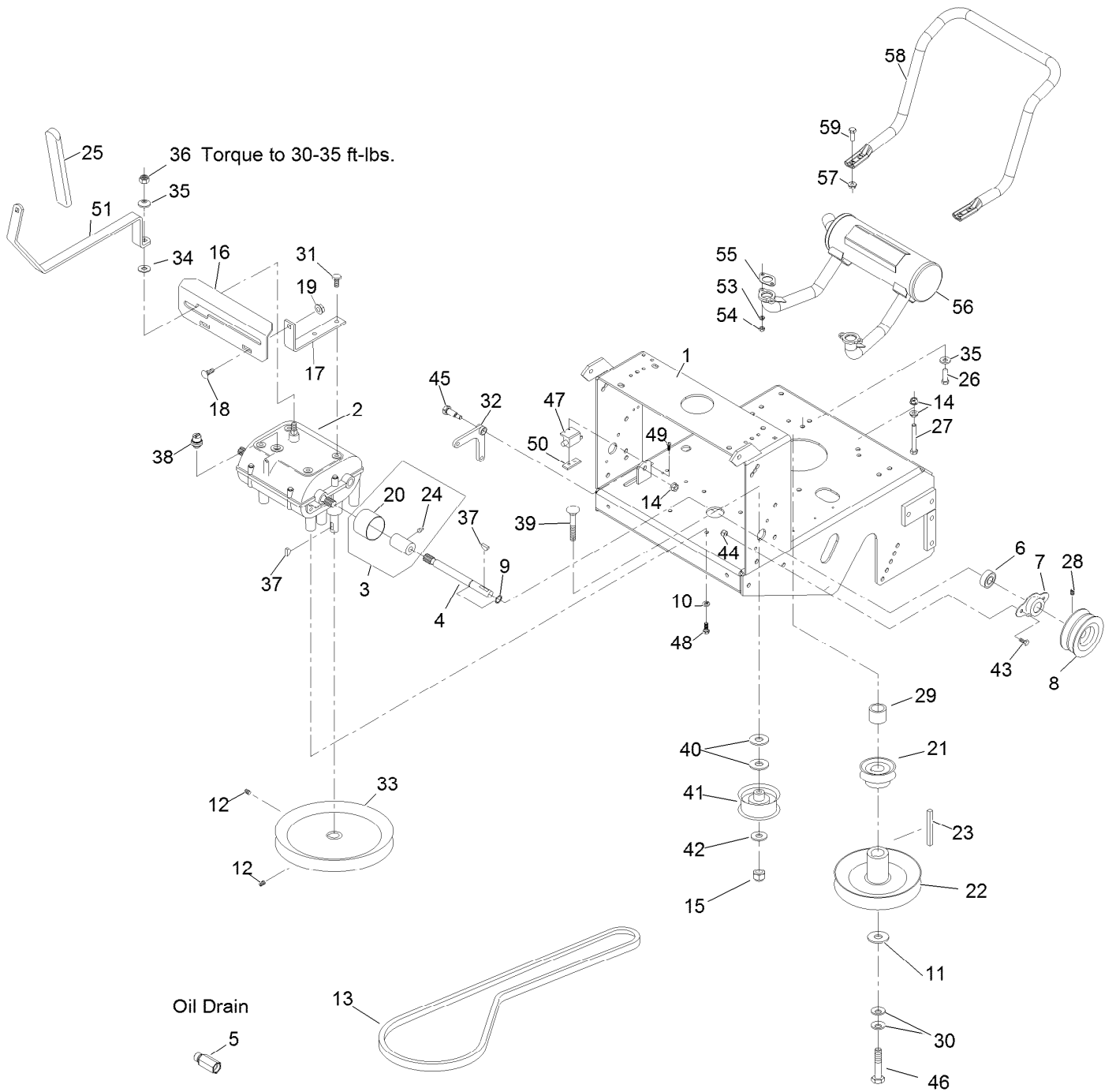

Engine Deck Assembly (continued)

<i>Ref.</i>	<i>Part Number</i>	<i>Qty.</i>	<i>Description</i>	<i>Ref.</i>	<i>Part Number</i>	<i>Qty.</i>	<i>Description</i>
1	116-6131	1	Rear Deck (116-6084-01) W/Decals	29	1-633453	1	Spacer-Clutch
2	1-323500	1	Transmission	30	1-603610	2	Washer-Spring Disc 7/16
3	1-324340	2	Coupling, W/Guard And Zerk	31	32144-11	4	Screw-HWH 5/16-18 X 3/4 Tf
4	1-323502	2	Shaft-Transmission	32	1-303186	1	Bellcrank
5	103-2587	1	Adapter	33	1-323278	1	Sheave-Transmission ●
6	1-323252	2	Bearing-Shaft ●	34	1-323379	1	Washer
7	1-323254	2	Flange-Output	35	98-5975	5	Washer-Spring Disc 3/8
8	103-6511	2	Sheave-Transmission ●	36	3296-6	1	Nut-Nyloc 3/8-24
9	32151-62	2	Ring-Retaining	37	3257-5	3	Key-Woodruff #9 3/4 X 3/16
10	1-805005	4	Washer-Lock 5/16 Heavy	38	1-303282	1	Switch-Start, Neutral
11	1-373034	1	Washer	39	3231-6	1	Bolt-Carriage 3/8-16 X 2
12	3245-41	2	Setscrew-1/4-20 X 3/8 ■	40	3256-5	2	Washer-7/16 Std
13	1-323280	1	Belt, Transmission Drive	41	1-323285	1	Pulley-Idler, Flat
14	3290-357	3	Nut-Whizlock 3/8-16	42	3256-24	1	Washer-3/8 Sae
15	3296-39	1	Nut-Nyloc 3/8-16	43	321-3	4	Screw-HH 1/4-20 X 5/8
16	103-3498	1	Asm, Shifter Plate (1-323387-03) W/ Decals	44	3296-42	4	Nut-Nyloc 1/4-20
17	1-323389-03	2	Bracket-Plate, Shift	45	1-603403	1	Bolt-Shoulder
18	3230-1	2	Bolt-Carriage 5/16-18 X 3/4	46	116-3702	1	Screw-HH ■
19	104-8300	2	Nut-Nyloc 5/16-18 Flg	47	1-513051	1	Switch-N.O.
20	51-4220	2	Guard-Coupler	48	322-3	4	Screw-HH 5/16-18 X 3/4
21	103-1666	1	Sheave-Transmission ●	49	3290-500	2	Screw-PPH #10-24 X 5/8
22	103-1667	1	Sheave ●	50	1-633181	1	Plate-Tapped
23	103-4177	1	Key	51	103-1606	1	Lever, Shift W/Grip
24	302-19	2	Zerk-1/4-28 Str	53	114-3550	4	Washer-Lock, Spring
25	103-1733	1	Grip Foam	54	114-3549	4	Nut-M8
26	323-7	4	Screw-HH 3/8-16 X 1 1/4	55	1-653313	2	Gasket-Exhaust
27	323-13	1	Screw-HH 3/8-16 X 2 3/4	56	116-3735	1	Muffler-Horizontal
28	3246-18	2	Setscrew-5/16-18 X 3/8 ■	57	104-8301	4	Nut-Nyloc 3/8-16 Flg
				58	116-6278-03	1	Guard-Muffler
				59	323-6	4	Screw-HH 3/8-16 X 1

● Apply anti-seize compound in bore.

■ Use Pro-Lock, Nut Type (P/N 1-840022, .5ml tube) on threads.

Engine Deck Assembly - (cont.)

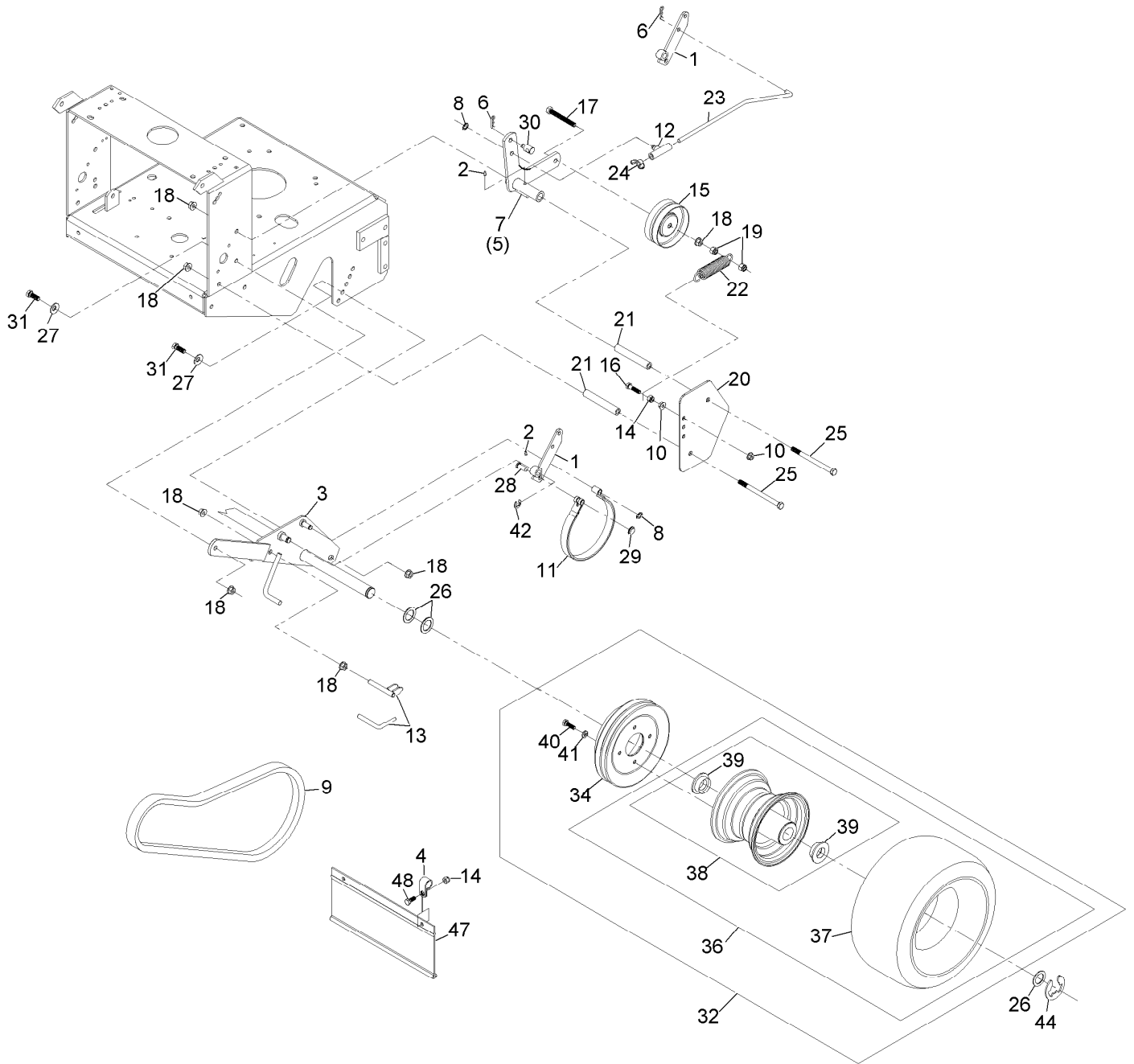

Engine Deck Assembly - (cont.) (continued)

<i>Ref.</i>	<i>Part Number</i>	<i>Qty.</i>	<i>Description</i>	<i>Ref.</i>	<i>Part Number</i>	<i>Qty.</i>	<i>Description</i>
1	103-1611-03	2	Arm-Brake	23	103-1620	1	Linkage,RH Brake
2	302-19	4	Zerk-1/4-28 Str	24	1-513959	2	Wingnut-Nyloc 5/16
3	1-322117-03	1	Axle	25	323-39	4	Screw-HH 3/8-16 X 5
4	2412-104	2	Clamp-R	26	1-523157	1	Washer ●
5	116-7542-03	1	Arm-Idler, LH	26	1-543436	1	Washer-Spacer ●
6	1-806003	4	Hairpin-Cotter	27	98-5975	4	Washer-Spring Disc 3/8
7	116-7543-03	1	Arm-Idler, RH	28	1-323307	2	Pin-Clevis 1/2 X 1
8	32151-47	4	Ring-Retaining	29	1-803051	2	Nut-Push 3/8
9	1-323288	2	Belt, Wheel Drive	30	103-1618	2	Swivel, Short
10	32128-20	4	Nut-Whizlock 5/16-18	31	323-6	4	Screw-HH 3/8-16 X 1
11	1-323262	2	Band-Brake	32	109-4721	2	Asm, Wheel Drive (36" And 48" Models)
12	110-5866	2	Swivel-Brake	34	109-4359	2	Drum And Sheave ASM
13	1-412358	2	Scraper	36	1-323719	2	Wheel And Tire ASM
14	3296-29	4	Nut-Nyloc 5/16-18	37	1-323720	1	Tire-Turfmaster
15	1-323277	2	Idler-Wheel, Drive	38	1-323328	1	Wheel And Hub ASM
16	322-6	2	Screw-HH 5/16-18 X 1 1/4	39	1-323329	4	Bearing-Flanged
17	99-8664	2	Bolt-HH 3/8-16 X 3 Tap	40	322-5	8	Screw-HH 5/16-18 X 1
18	3290-357	14	Nut-Whizlock 3/8-16	41	1-805005	8	Washer-Lock 5/16 Heavy
19	3296-39	4	Nut-Nyloc 3/8-16	42	32120-47	2	Ring-Retaining
20	1-323287-01	2	Shield-Wheel, Drive	44	1-808519	2	Ring-Snap
21	1-323283	4	Spacer-Shield	47	98-3259	1	Shield-Trailing
22	1-603402	2	Spring-Extension	48	322-3	2	Screw-HH 5/16-18 X 3/4
23	103-1619	1	Linkage,LH Brake				

● QTY As Required

ECS Upper Handle and Controls

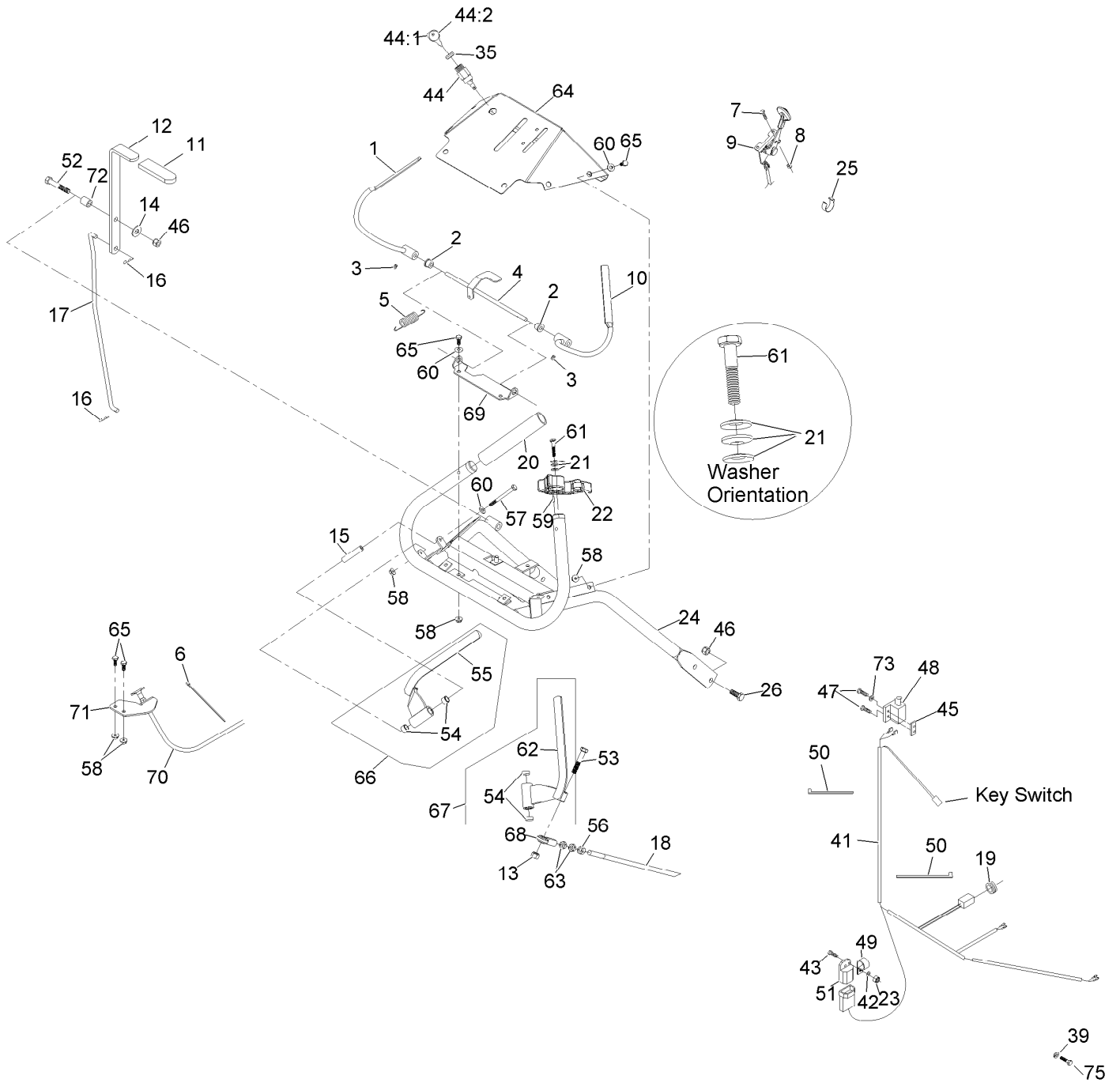

ECS Upper Handle and Controls (continued)

<i>Ref.</i>	<i>Part Number</i>	<i>Qty.</i>	<i>Description</i>	<i>Ref.</i>	<i>Part Number</i>	<i>Qty.</i>	<i>Description</i>
1	116-4079	1	Wld, Lever, Opc (LH) ▲	44:1	1-603511	1	Keys-Ignition (Spare Pair)
2	1-303365	2	Bushing-Nylon	44:2	103-2106	1	Key,Exmark Logo
3	1-803322	2	Screw-Set ■	45	1-633181	1	Plate-Tapped
4	103-0769-03	1	Rod Weldment, Opc	46	3296-39	5	Nut-Lock, NI
5	1-303363	1	Spring-Extension	47	3290-500	2	Screw-PPH
6	1-303335	1	Tie-Plastic	48	1-513051	1	Switch-Open, Normally
7	1-807513	2	Bolt-CARR	49	1-513762	1	Clip-Loom
8	3296-2	2	Nut-Lock, NI	50	1-303287	6	Tie-Cable
9	116-2426	1	Cable, Throttle	51	1-323430	1	Module-Interlock
10	116-4080	1	Wld, Opc Lever (RH) ▲	52	323-14	1	Screw-HH
11	1-303020	1	Grip-Lever	53	322-9	2	Screw-HH
12	103-1629	1	Clutch Lever W/Grip	54	1-413152	4	Bushing-Sleeve
13	3296-29	2	Nut-Lock, NI	55	116-4081-03	1	Lever, Drive LH
14	3256-4	1	Washer-Flat	56	3219-3	2	Nut-Hex
15	103-0027	2	Bushing-Lever, Drive	57	321-14	2	Screw-HH
16	1-806003	2	Pin-Cotter, Hair	58	32128-33	12	Nut-HF
17	103-1627	1	Linkage, Upper	59	103-0464	2	Pin-Spring
18	103-1604	2	Linkage, Wheel Drive	60	3256-22	10	Washer-Flat
19	1-543296	1	Grommet	61	103-0235	2	Screw-HH ■
20	103-0815	2	Grip-Bar, Handle	62	116-4082-03	1	Lever, Drive RH
21	1-303435	6	Washer-Spring	63	3220-3	4	Nut-HJ
22	103-1631	1	Latch, Thumb LH ●	64	109-4934	1	Asm, Console (109-4649-03) W/Decals
22	103-1630	1	Latch, Thumb RH				
23	3296-42	1	Nut-Lock, NI	65	321-3	10	Screw-HH
24	103-0770-03	1	Handle Weldment (1-412449)	66	103-2513	1	Asm, Drive Lever RH
25	1-303088	1	Clip-Cable	67	103-2514	1	Asm, Drive Lever LH
26	323-6	4	Screw-HH	68	103-2463	2	Joint, .31 Ball End
35	103-0498	1	Nut-Switch, Ignition	69	103-0489-03	1	Bracket, Opc Axle
39	33094-00	1	Washer-Plain	70	103-1796	1	Cable-Choke
41	116-2661	1	Harness-Wire	71	103-1797-01	1	Bracket-Cable, Choke
42	3256-22	1	Washer-Flat	72	1-633080	1	Bushing-Lever, Lift
43	321-4	1	Screw-HH	73	3256-14	1	Washer-Flat
44	1-403121	1	Switch-Key	75	33114-016	1	Screw-HH

● Not illustrated

■ Use Pro-Lock, Nut Type (P/N 1-840022, .5ml tube) on threads.

▲ Use Pro-Lock retaining type, Part no. 1-840023 (.5cc tube) on inside of bore of OPC hub.

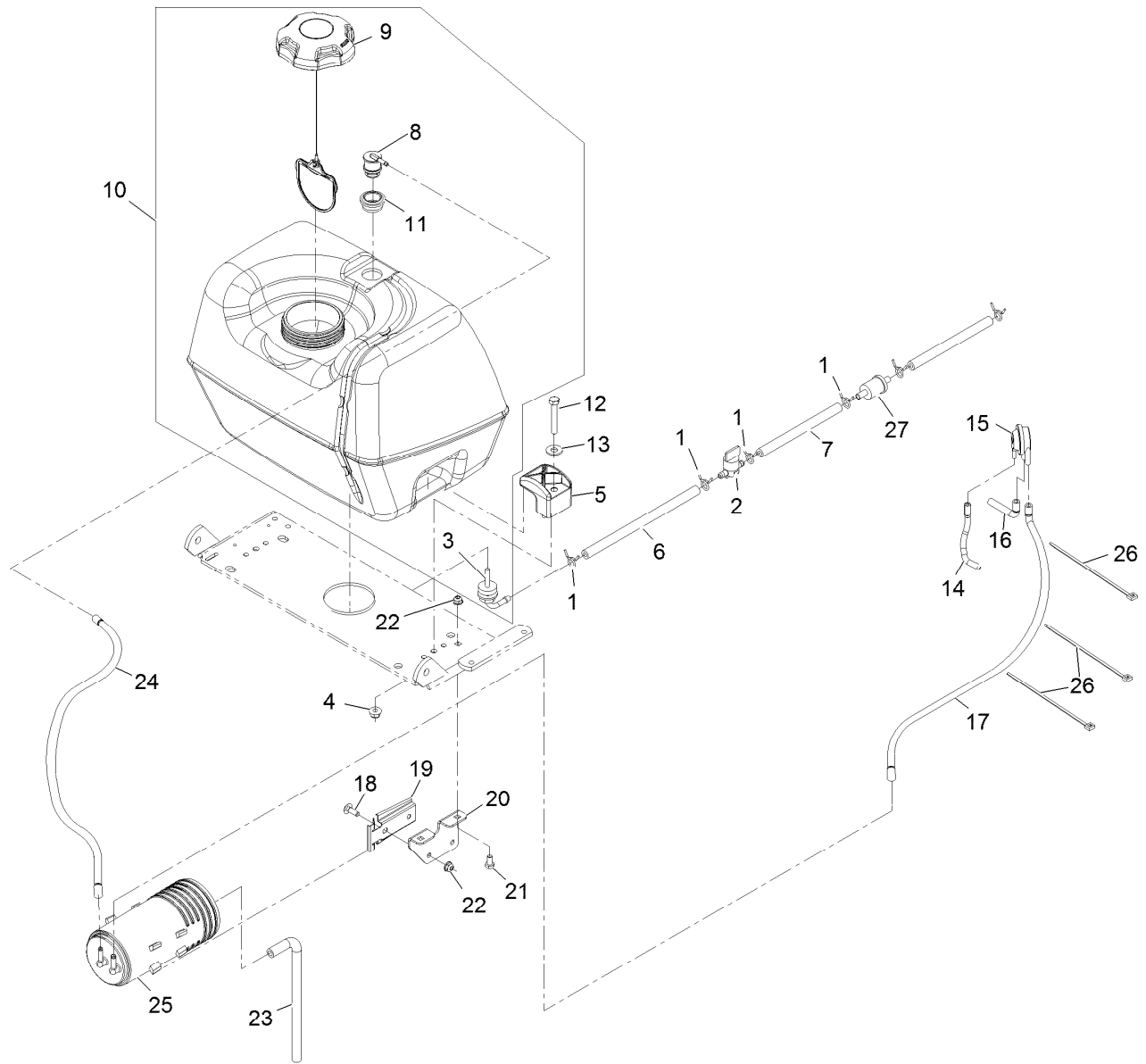

Fuel Tank Assembly

Ref.	Part Number	Qty.	Description	Ref.	Part Number	Qty.	Description
1	2412-98	4	Clamp-Hose	15	116-2232	1	Valve-Control, Vacuum
2	1-603770	1	Valve-Fuel	16	116-2233	1	Hose-Vent, Formed
3	103-2605	1	Fitting-Fuel, Bulkhead ▲	17	116-2231	1	Hose-Vent, Formed
4	104-8300	2	Nut-Flange, NI	18	321-2	2	Screw-HH
5	107-4543	2	Clamp	19	114-0292	1	Bracket-Canister, Carbon
6	109-0650	1	Hose-Fuel	20	115-4486-01	1	Bracket-Canister, Carbon
7	99-9415	1	Hose-Fuel	21	3229-1	2	Bolt-CARR
8	119-3547	1	Valve-Vent, Fuel	22	104-7201	4	Nut-HF
9	120-5461	1	Cap-Fuel, Ratcheting	23	115-0962	1	Hose-Vent, Canister
10	126-1525	1	Asm-Fuel Tank	24	114-0286	1	Hose-Vent
11	114-0284	1	Grommet	25	117-1221	1	Canister-Carbon, 800Cc
12	322-10	2	Screw-HH	26	1-303335	3	Tie-Plastic
13	3256-3	2	Washer-Flat	27		1	Pn 41019-1055 Filter W/6In Fuel Line ■●
14	116-2394	1	Hose-Vent, Formed				

● Not serviced separately

▲ Use Pro-Lock, Nut Type (P/N 1-840022, .5ml tube) on threads.

■ Obtain parts from www.kawpowerpc.com

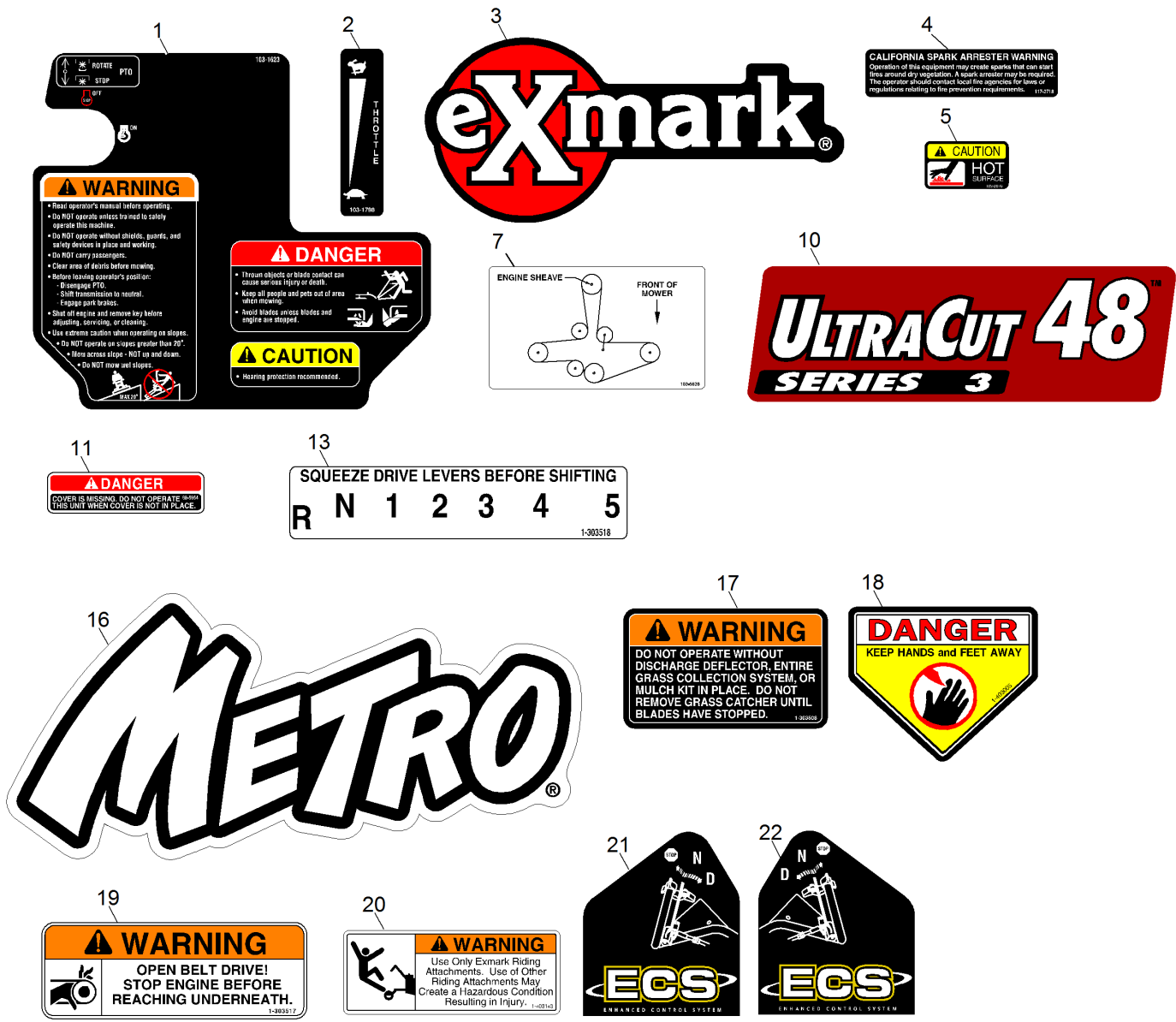

Decals

Ref.	Part Number	Qty.	Description
1	103-1623	1	Decal, Console
2	103-1798	1	Decal, Throttle
3	103-2882	1	Decal, Exmark Logo
4	117-2718	1	Decal-Arrester, Spark
5	103-2076	2	Decal-Caution
7	103-5626	1	Decal, Belt Routing (48")
10	116-4697	1	Decal-Ultracut 48 Series 3
11	98-5954	1	Decal-Cover, Missing
13	1-303518	1	Decal, Shifter

Ref.	Part Number	Qty.	Description
16	103-2920	1	Decal, Metro Model
17	1-303508	1	Decal-Warning, Discharge
18	1-403005	2	Decal-Danger
19	1-303517	1	Decal,Belt Drive
20	1-403143	1	Decal, Sulky Warning
21	103-2245	1	Decal, RH Ecs Instruction
22	103-2244	1	Decal, LH Ecs Instruction
99	103-2640	1	Decal, Kit ●

● Not illustrated

Notes:

EXMARK® MAINTENANCE

MAXIMIZE THE PERFORMANCE OF YOUR EXMARK.

4-CYCLE PREMIUM ENGINE OIL

Part No. 116-3373

Both SAE 30 and SAE 10W-30 in one bottle.

Contains increased levels of zinc and phosphorus for better lubricity.

No Viscosity Index Improvers that tend to shear down in high heat.

Synthetic formulation.

Gas & Diesel compatible.

Anti-corrosion additives.

API 'SL' and JASO rated with wet clutch compatibility for other machines.

PREMIUM HYDRO OIL

Part No. 109-9828

Commercial quality for tough, high-heat conditions.

Designed specifically for zero-turn mower hydraulic systems.

Superior shear resistance under heavy loads.

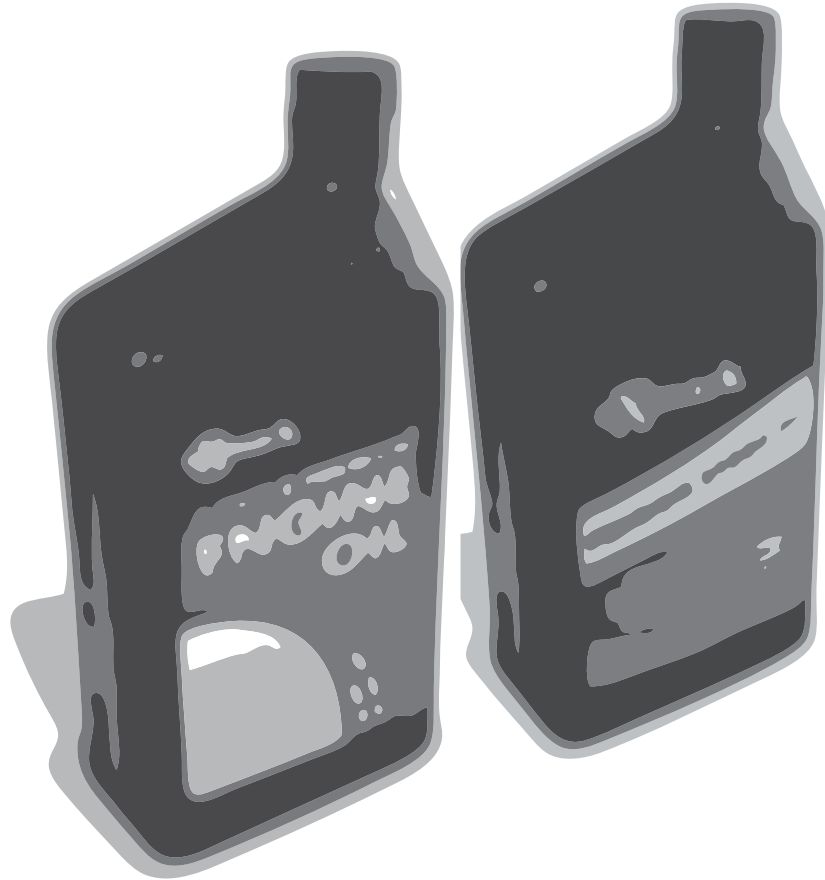

Available from your local Exmark dealer. Find your closest dealer at exmark.com

EXMARK ACCESSORIES AND OPTIONS*

MID-MOUNT RIDING ACCESSORIES AND OPTIONS

CUSTOM RIDE SEAT SUSPENSION SYSTEM	OPERATOR CONTROLLED DISCHARGE
FULL SUSPENSION SEAT	SUN SHADE
DECK LIFT ASSIST KIT	TRASH CONTAINER
HITCH KIT	TURF STRIPER
LIGHT KIT	ULTRA VAC COLLECTION SYSTEM
12V POWER PORT	ULTRA VAC QUICK DISPOSAL SYSTEM
MICRO-MULCH SYSTEM	

OUT-FRONT RIDING ACCESSORIES AND OPTIONS

CUSTOM RIDE SEAT SUSPENSION SYSTEM	SNOW BLADE
DUAL-TAIL WHEEL	SNOWBLOWER
FLOOR PAN EXTENDER	SUN SHADE
HITCH KIT	TRASH CONTAINER
LIGHT KIT	ULTRA VAC COLLECTION SYSTEM
MICRO-MULCH SYSTEM	ULTRA VAC QUICK DISPOSAL SYSTEM
ROLL OVER PROTECTION SYSTEM (ROPS)	WEATHER CAB

WALK-BEHIND ACCESSORIES AND OPTIONS

GRASS CATCHER	TURF STRIPER
MICRO-MULCH SYSTEM	STANDON

*Some accessories and options not available for some models.

Place Model No. and Serial No.
Label Here (Included in the Literature
Pack) or Fill in Below

Model No. _____

Serial No. _____

Date Purchased _____

Engine Model No. and Spec. No. _____

Engine Serial No. (E/No) _____

© 2013 Exmark Mfg. Co., Inc.
Industrial Park Box 808
Beatrice, NE 68310
All Rights Reserved

Part No. 4501-697 Rev. A
(402) 223-6300
Fax (402) 223-5489
Printed in the USA.

