

(19)



(11)

EP 3 439 456 B1

(12)

EUROPEAN PATENT SPECIFICATION

(45) Date of publication and mention of the grant of the patent:
08.09.2021 Bulletin 2021/36

(51) Int Cl.:
A01D 45/02 ^(2006.01) **A01D 43/08** ^(2006.01)
A01F 17/02 ^(2006.01)

(21) Application number: **17779631.5**

(86) International application number:
PCT/US2017/025884

(22) Date of filing: **04.04.2017**

(87) International publication number:
WO 2017/176705 (12.10.2017 Gazette 2017/41)

(54) **CHOPPER ASSEMBLY WITH FULL MECHANICAL TRANSPORT**

HÄCKSLERANORDNUNG MIT VOLLMECHANISCHEM TRANSPORT

ENSEMBLE HACHEUR AVEC TRANSPORT MÉCANIQUE COMPLET

(84) Designated Contracting States:
AL AT BE BG CH CY CZ DE DK EE ES FI FR GB GR HR HU IE IS IT LI LT LU LV MC MK MT NL NO PL PT RO RS SE SI SK SM TR

(74) Representative: **Engelhard, Markus Boehmert & Boehmert Anwaltspartnerschaft mbB Pettenkoflerstrasse 22 80336 München (DE)**

(30) Priority: **04.04.2016 US 201662317714 P**
03.04.2017 US 201715477823

(56) References cited:
EP-A1- 0 787 426 US-A- 1 744 335
US-A- 2 380 347 US-A- 4 148 175
US-A- 4 510 948 US-A- 4 696 432
US-A- 5 863 005 US-A1- 2008 000 207
US-A1- 2008 248 843 US-A1- 2014 053 523
US-A1- 2016 081 272

(43) Date of publication of application:
13.02.2019 Bulletin 2019/07

(73) Proprietor: **Straeter, James E. Rochester, Indiana 46975 (US)**

(72) Inventor: **Straeter, James E. Rochester, Indiana 46975 (US)**

EP 3 439 456 B1

Note: Within nine months of the publication of the mention of the grant of the European patent in the European Patent Bulletin, any person may give notice to the European Patent Office of opposition to that patent, in accordance with the Implementing Regulations. Notice of opposition shall not be deemed to have been filed until the opposition fee has been paid. (Art. 99(1) European Patent Convention).

Description

BACKGROUND OF THE INVENTION

[0001] This invention is directed to a chopping assembly, and more particularly to a chopping assembly that provides mechanical control of moving chopped product throughout the system. EP 0 787 426 A1 relates to chopper assemblies comprising a blade assembly disposed within a housing.

[0002] US 2008/000207 A1 relates to crop processing devices comprising a pick-up unit and a cutting unit.

[0003] Chopping assemblies are known in the art for processing corn stalks and other crops for a desired use. Typically, a stover chopping assembly is mounted to a harvesting corn header and includes a blade assembly disposed within a housing in communication with a discharge channel or conduit that leads to a conveyor. While useful, chopped crop product occasionally plugs in the discharge conduit especially in difficult, wet conditions or material is lost from the chopper when moved through an open space between the chopper and conveyor such as with the product design used by Geringhoff. When a plug occurs the operation of the header and combine is halted and often the operator must manually remove a plug, leading to lost time and considerable interruption of the harvesting operation. The plug removal usually requires the operator to leave the cab of the combine, thus creating more delay and effort. Providing a system that limits or eliminates lost material while providing plug-free operation or easy unplugging therefore is needed.

[0004] Thus, an object of the present invention is to provide a chopping assembly where a harvester need not be slowed or stopped to remove a plug in a discharge conduit.

[0005] Another objective of the present invention is to provide a chopping assembly where plugs are removed automatically, without manual assistance, in a process of header reversal that is used to unplug areas of the header not associated with the chopper.

[0006] Another objective of the present invention is to provide a means of transport that has no part of the transport path of the chopped material where it is moved solely by momentum or air and movement is always being controlled by a mechanical means.

[0007] Another objective of the present invention is to provide a mechanical transport means that has open paths for material coming off of the chopping knives to go directly to the conveyor without solely mechanical movement.

SUMMARY OF THE INVENTION

[0008] A chopper assembly having a blade assembly disposed within a housing having a discharge port. Mounted to the housing and in communication with the discharge port is a discharge conduit.

[0009] Rotatably mounted within the discharge conduit

are two beaters. The beaters preferably have a plurality of paddles mounted to a rotatable shaft. Positioned below the first beater in a bottom wall of the discharge conduit is a first door. The first door pivots downwardly from a closed to an open position. Positioned below the second beater in the bottom wall of the discharge conduit is a second door. The second door pivots upwardly between the first and the second beater from a closed to an open position.

BRIEF DESCRIPTION OF THE DRAWINGS

[0010]

Fig. 1 is a top plan view of a chopper assembly; and Fig. 2 is a side sectional view of a chopper assembly.

DETAILED DESCRIPTION OF THE PREFERRED EMBODIMENT

[0011] Referring to the figures, a chopping assembly 10 has a blade assembly 12 disposed within a housing 14. The blade assembly is of any type and as shown by example only, have the structure of the blade assemblies disclosed in U. S. Patent Nos. 7,856,800, 8,087,223, and 8,141,332, herein incorporated by reference in their entireties. Generally, the blade assembly 12 includes a plurality of blades 16 that are attached to and extend radially and outwardly from a drive shaft 18.

[0012] The housing 14 has a top wall 20 connected to a harvesting implement (not shown) with an opening 22 through which drive shaft 18 extends. The housing also has an arcuate side wall 24 and a bottom wall 26 having an opening 28 and a slot 30. The side wall 24 has an inlet port 32 and a discharge port 34. Extending outwardly from the inlet port 32 of housing 14 are guide members 36.

[0013] Mounted to an in communication with the discharge port 34 is an elongated discharge conduit 38. The discharge conduit 38 has a top wall 40, side walls 42, and a bottom wall 44. Rotatably mounted to and extending between side walls 42 is a first beater 46 and a second beater 48. The beaters 46 and 48 are of any type and, in one example, have a plurality of paddles 50 mounted to a shaft 52 that extends through side walls 42. In a preferred embodiment, the beaters 46 and 48 have two paddles 50 with a plurality of teeth 54 on an outer edge. The paddles 50 preferably dwell in the same plane on opposite sides of shaft 52. The beaters 46 and 48, in one example, spaced to avoid contact with each other but separated with minimal distance. Also, beater 46 is positioned adjacent to blades 16 to minimize any gap between the two to eliminate a non-active area where stover could plug. Further, the beaters 46 and 48 preferably are timed so that all paddles dwell in a horizontal plane at a 3 o'clock and 9 o'clock position and are in a parallel vertical spaced relation at a 12 o'clock and 6 o'clock position. The beaters 46 and 48 and the blade assemblies 12 are

mechanically driven and controlled by the operation of a corn header (not shown).

[0014] The bottom wall 44 of discharge conduit 38 has a first door 55 and a second door 56 positioned below the first beater 46 and second beater 48, respectively. Both doors 55 and 56 have actuators 58 that move the doors from a closed position to an open position or are controlled by a single actuator and are mechanically connected. The first door 55 pivots downwardly in relation to the discharge conduit 38 to move from a closed to an open position. The second door 56 pivots upwardly into the discharge conduit 38 and between the first beater 46 and the second beater 48 when the door 56 moves from a closed to an open position. At an end opposite of the blade assembly 12, the discharge conduit 38 is connected to and in communication with a discharge conveyor 60.

[0015] The door actuators 58 are connected to a micro-controller 62. The micro-controller 62 controls the activation of actuators 58.

[0016] In operation, as the harvesting implement moves forward, a stalk or stem of a harvested plant is directed by guide members 36 to the inlet port 32 of housing 14. As the stalk or stem enters the inlet port 32, it is captured in slot 30 where the blades 16, rotated by drive shaft 18, cuts the plant from its roots and further cuts the stalk into chopped stover. The rotation of the blades 16, with the assistance of the housing 14, moves the chopped stover through the discharge port 34 and into the discharge conduit 38. The first beater 46 and second beater 48 transport stover through the discharge conduit 38 to the discharge conveyor 60 mechanically. The discharge conveyor 60 transports the stover to a windrow position. In this manner, stover is positively and mechanically transported from the blades to the beaters and to the discharge conveyor instead of relying upon momentum and/or air flow.

[0017] If the discharge conduit 38 becomes plugged, an operator utilizing existing driveline capabilities of the corn header, reverses the corn header which reverses the rotational direction of beaters 46 and 48, material is driven back toward the blades and either falls on the ground or is discharged through the inlet of the blade assembly.

[0018] Also, if the discharge conduit 38 becomes plugged with stover, or if one does not wish to take all the stover to windrow using the micro-controller 62, an operator activates actuators 58 which moves doors 55 and 56 from a closed to an open position. When in an open position, the front door 55 goes down providing greater area under the first beater 46 and permits stover to be transported to the ground. The second door 56 moves upwardly into the discharge conduit 38 between the first beater 46 and the second beater 48 and provides a dam directing stover out of conduit 38. This process allows a plug to be discharged through the first door 55 opening without disrupting the harvesting process by providing a positive discharge where the beater 46 drives

material through the first door 55.

[0019] To take advantage of the considerable velocity of material coming off the chopper knives, the beaters 46 and 48 can be timed such that at one part of their rotation both beaters have blades 50 that are horizontal, thereby opening a path above shaft 52 and below shaft 52 where material can move directly to conveyor 60 unimpeded. As beaters 46 and 48 continue their rotation, any material in tunnel 38 that didn't move all the way to conveyor 60 is positively moved toward the conveyor 60. In this manner material is quickly and positively moved from the chopper to the conveyor with no chance of plugging.

[0020] Therefore, a chopper assembly has been disclosed that at the very least meets all the stated objectives.

Claims

1. A chopper assembly (10), comprising;
 - a blade assembly (12) disposed within a housing (14) having a discharge port (34);
 - a discharge conduit (38) mounted to the housing (14) and in communication with the discharge port (34); and
 - characterized by** a first beater (46) and a second beater (48) rotatably mounted within the discharge conduit (38), wherein the discharge conduit (38) has a bottom wall (44) with a first door (55) positioned below the first beater (46) and a second door (56) positioned below the second beater (48), wherein the second door (56) pivots upwardly between the first beater (46) and the second beater (48).
2. The assembly (10) of claim 1 wherein the first beater (46) and the second beater (48) each have a plurality of paddles (50) mounted to a shaft (52).
3. The assembly (10) of claim 1 wherein the first beater (46) and the second beater (48) each have two paddles (50) mounted to a shaft (52) that dwell in the same plane on opposite sides of the shaft (52).
4. The assembly (10) of claim 1 wherein the first beater (46) and the second beater (48) each have a plurality of paddles (50) mounted to the shaft (52) and the plurality of paddles (50) have teeth (54) on an outer edge.
5. The assembly (10) of claim 1 wherein the first beater (46) and the second beater (48) have a rotational diameter where the first beater (46) and the second beater (48) cannot contact each other but have a minimal distance between them.

6. The assembly (10) of claim 1 wherein the first beater (46) and the second beater (48) each have a plurality of paddles (50) mounted to a shaft (52) that are timed to dwell in a horizontal plane at a 3 o'clock and a 9 o'clock position and in a parallel vertical spaced relation at a 12 o'clock and 6 o'clock position.
7. The assembly (10) of claim 1 wherein the first door (55) in the bottom wall (44) pivots downwardly from a closed position to an open position.

Patentansprüche

1. Häckselanordnung (10), umfassend:

eine Klingenanordnung (12), die innerhalb eines Gehäuses (14) mit einer Abgabeöffnung (34) angeordnet ist;

eine Abgabelleitung (38), die an dem Gehäuse (14) montiert ist und in Kommunikation mit der Abgabeöffnung (34) steht; und

gekennzeichnet durch einen ersten Schlegel (46) und einen zweiten Schlegel (48), die drehbar innerhalb der Abgabelleitung (38) montiert sind,

wobei die Abgabelleitung (38) eine Bodenwand (44) mit einer ersten Tür (55), die unter dem ersten Schlegel (46) positioniert ist, und einer zweiten Tür (56), die unter dem zweiten Schlegel (48) positioniert ist, aufweist, wobei die zweite Tür (56) zwischen dem ersten Schlegel (46) und dem zweiten Schlegel (48) nach oben schwenkt.

2. Anordnung (10) nach Anspruch 1, wobei der erste Schlegel (46) und der zweite Schlegel (48) jeweils eine Vielzahl von Schaufeln (50) aufweisen, die an einem Schaft (52) montiert sind.
3. Anordnung (10) nach Anspruch 1, wobei der erste Schlegel (46) und der zweite Schlegel (48) jeweils zwei an einem Schaft (52) montierte Schaufeln (50) aufweisen, die in derselben Ebene auf gegenüberliegenden Seiten des Schafts (52) liegen.
4. Anordnung (10) nach Anspruch 1, wobei der erste Schlegel (46) und der zweite Schlegel (48) jeweils eine Vielzahl von Schaufeln (50) aufweisen, die an dem Schaft (52) montiert sind, und die Vielzahl von Schaufeln (50) Zähne (54) an einem äußeren Rand aufweist.
5. Anordnung (10) nach Anspruch 1, wobei der erste Schlegel (46) und der zweite Schlegel (48) einen Drehdurchmesser aufweisen, wobei der erste Schlegel (46) und der zweite Schlegel (48) einander nicht kontaktieren können, sondern eine minimale Distanz dazwischen aufweisen.

6. Anordnung (10) nach Anspruch 1, wobei der erste Schlegel (46) und der zweite Schlegel (48) jeweils eine Vielzahl von an einem Schaft (52) montierten Schaufeln (50) aufweisen, die darauf abgestimmt sind, in einer horizontalen Ebene in einer Stellung von 3 Uhr und von 9 Uhr und in einer parallelen vertikalen beabstandeten Beziehung in einer Stellung von 12 Uhr und von 6 Uhr zu liegen.
7. Anordnung (10) nach Anspruch 1, wobei die erste Tür (55) in der Bodenwand (44) aus einer geschlossenen Position in eine offene Position nach unten schwenkt.

Revendications

1. Ensemble hacheur (10) comprenant :

un ensemble de lame (12) disposé à l'intérieur d'un boîtier (14) ayant un orifice de décharge (34) ;

un conduit de décharge (38) monté sur le boîtier (14) et en communication avec l'orifice de décharge (34) ; et

caractérisé par un premier batteur (46) et un second batteur (48) montés en rotation à l'intérieur du conduit de décharge (38),

dans lequel le conduit de décharge (38) a une paroi inférieure (44) avec une première porte (55) positionnée au-dessous du premier batteur (46) et une seconde porte (56) positionnée au-dessous du second batteur (48), dans lequel la seconde porte (56) pivote vers le haut entre le premier batteur (46) et le second batteur (48).

2. Ensemble (10) selon la revendication 1, dans lequel le premier batteur (46) et le second batteur (48) ont chacun une pluralité de palettes (50) montées sur un arbre (52).
3. Ensemble (10) selon la revendication 1, dans lequel le premier batteur (46) et le second batteur (48) ont chacun deux palettes (50) montées sur un arbre (52) qui s'étendent dans le même plan sur les côtés opposés de l'arbre (52).
4. Ensemble (10) selon la revendication 1, dans lequel le premier batteur (46) et le second batteur (48) ont chacun une pluralité de palettes (50) montées sur l'arbre (52) et la pluralité de palettes (50) ont des dents (54) sur un bord externe.
5. Ensemble (10) selon la revendication 1, dans lequel le premier batteur (46) et le second batteur (48) ont un diamètre de rotation où le premier batteur (46) et le second batteur (48) ne peuvent pas être en contact entre eux, mais ont une distance minimale entre eux.

6. Ensemble (10) selon la revendication 1, dans lequel le premier batteur (46) et le second batteur (48) ont chacun une pluralité de palettes (50) montées sur un arbre (52) qui sont synchronisées pour s'étendre dans un plan horizontal à 3 heure et dans une position à 9 heure et dans une relation espacée verticale parallèle dans une position à 12 heure et une position à 6 heure.
7. Ensemble (10) selon la revendication 1, dans lequel la première porte (55) dans la paroi inférieure (44) pivote vers le bas d'une position fermée à une position ouverte.

5

10

15

20

25

30

35

40

45

50

55

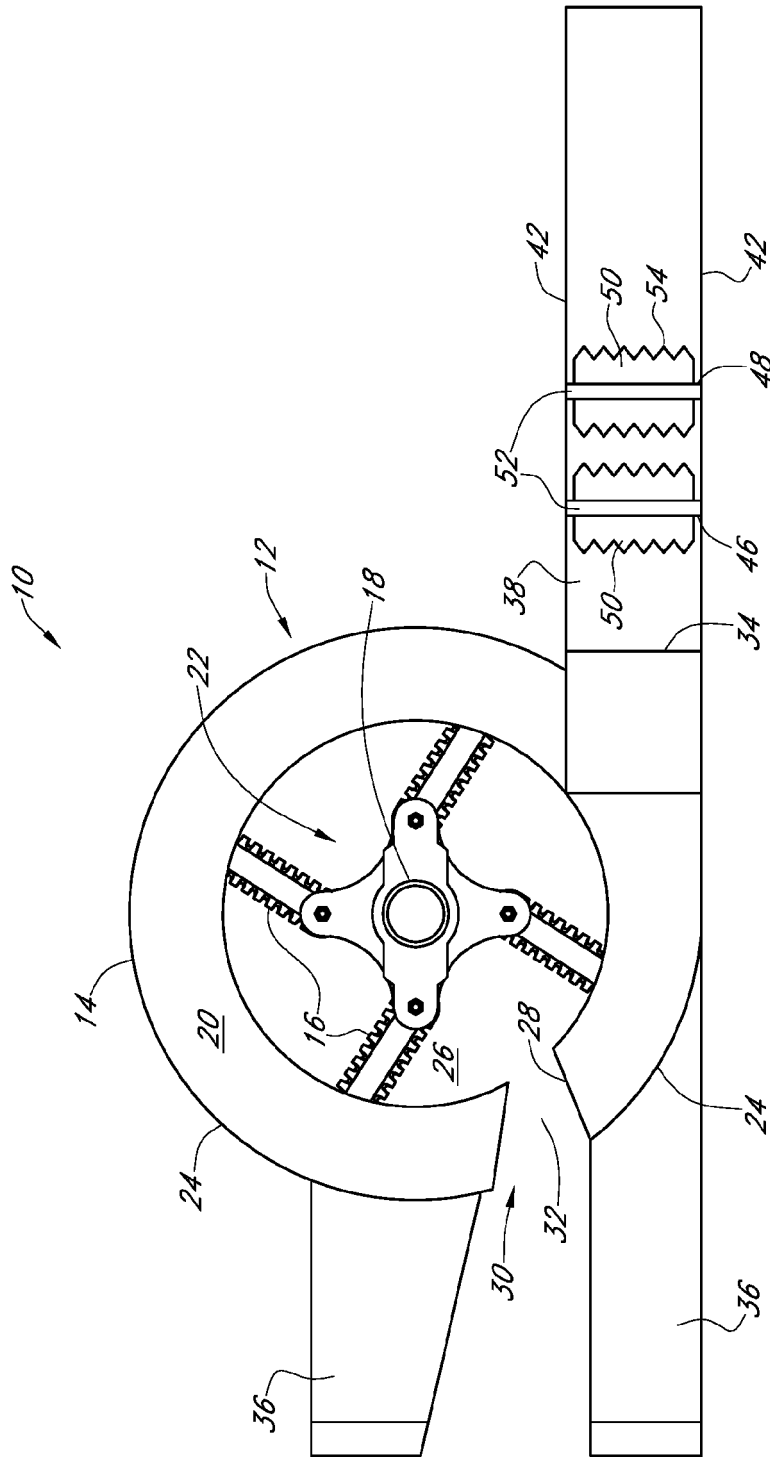

FIG. 1

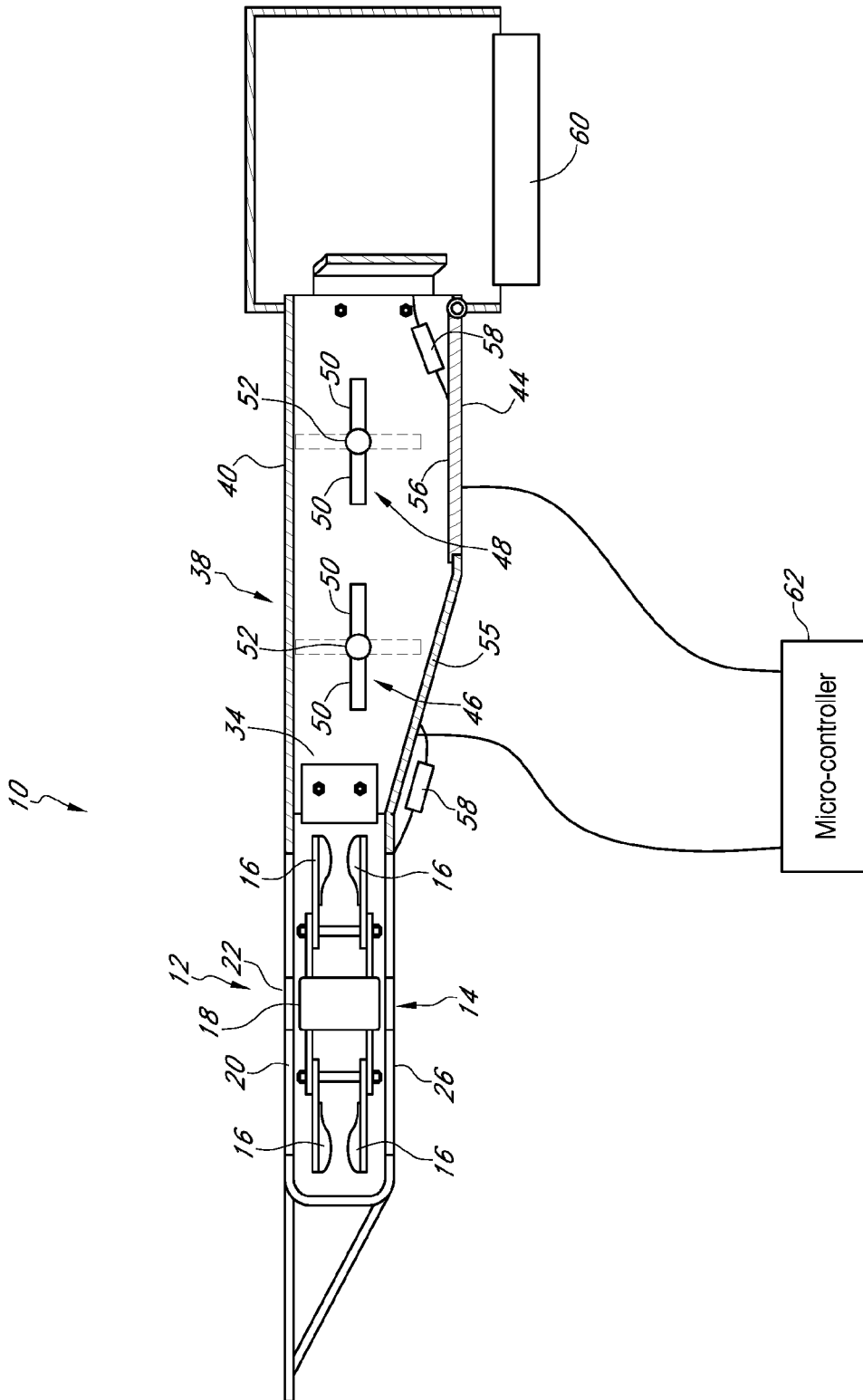

FIG. 2

REFERENCES CITED IN THE DESCRIPTION

This list of references cited by the applicant is for the reader's convenience only. It does not form part of the European patent document. Even though great care has been taken in compiling the references, errors or omissions cannot be excluded and the EPO disclaims all liability in this regard.

Patent documents cited in the description

- EP 0787426 A1 [0001]
- US 2008000207 A1 [0002]
- US 7856800 B [0011]
- US 8087223 B [0011]
- US 8141332 B [0011]