

# INSTRUCTIONS & INFORMATION



## DOZER/SNOWTHROWER CART

Kit Number 503273

(used with Dozer Blade and Snowthrowers)

This kit is used to assist with the removal and reinstallation of the Dozer Blade or the Models 412 and 512 Snowthrower on a Front Mount Grasshopper Tractor. The initial attachment installation should be on the tractor.

### ASSEMBLY INSTRUCTIONS:

(Refer to illustration on page 4)

- The Dozer/Snowthrower Cart may have been assembled at the factory.
- If assembly is required locate the Cart Pan (item 1) and the two .625" Rods (item 3). Slide the rods through the .625" holes in the sides of the pan. Rods should extend an equal distance from each side of pan. Secure each rod in place with two U-bolts (item 4) and .25-20 whiz nuts (item 8).
- Install a roller (item 5), with a .625" washer (item 6) on each side, onto each end of the rods. Secure rollers and washers with .156 x 1.25" cotter pins (item 7).
- Locate the cart's Upright (item 2) and attach it to the inside of pan as shown per illustration. Install a nylon washer (item 11) on each side of the legs of the upright and secure each leg with .312-18 x 1 bolt (item 9), flat washer (item 10) and .312 lock nut (item 12). Do not over tighten nuts as the upright will need to rotate up and down. (The illustration below shows the upright in the down position.)

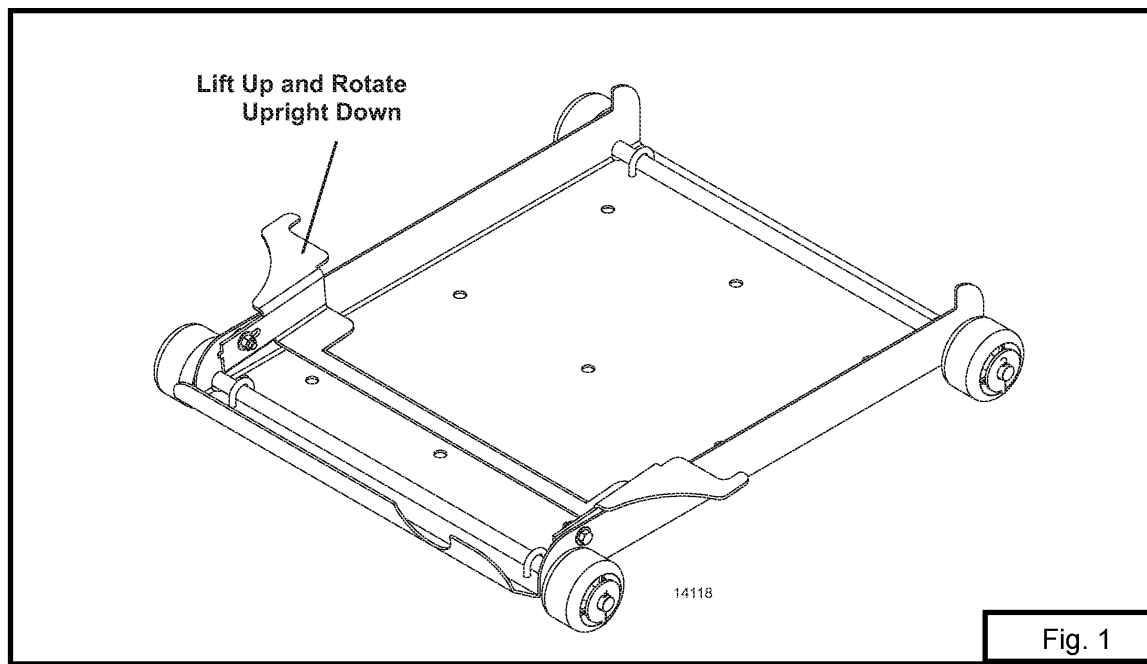

Fig. 1