

INSTRUCTIONS & INFORMATION



WORKLAMP KIT

Kit Number 503307

Used on 200V and M1 models with serial number 5300000 and above.

Used on all 200V-G4 & 500V models.

(snap mount style lights)

INSTALLATION INSTRUCTIONS

- Remove the fenders from the tractor and remove the worklamp filler panel from the fenders.
- Install blue push connectors from headlight harness (item 2) onto the terminals of the worklamp (item 3) assembly.
- Install the bezel in the front of the fender.
- Snap the worklamp assembly into the bezel. It works best to snap one side in at a time. When installing the worklamp assembly into the fender, be sure the green wire is to the top.
- Insert 2-way connector from tractor harness into connector from worklight harness (item 2).
- Remove the light switch hole plug. Locate the unused black wire from the circuit board. Route this wire through the light switch hole and connect it to the bottom post of the light switch (item 1). Locate the push-on terminal with the black wire(s) and install this terminal on the other post of the light switch.
- Make certain all wires have been routed to prevent chafing and any excess length of wire has been tied to stay clear of all moving parts and pinch points.
- Install light switch in the control panel and check worklamp operation.
- Reinstall the fenders on the tractor.

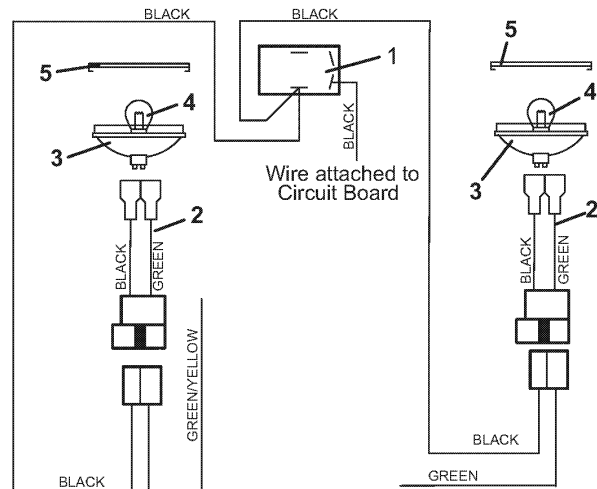
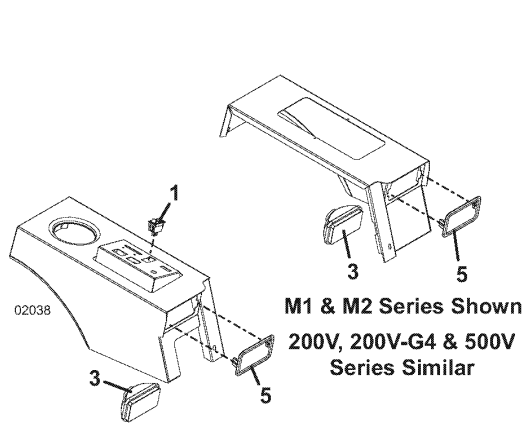

Item No.	Order No.	Description	Item No.	Order No.	Description
1	184179	Switch - Rocker	4	182005	Light Bulb - Worklamp
2	604893	Worklamp Harness	5	182251	Bezel - Snap Mount Worklamp
3	182253	Worklamp - Flood (includes item 4)			